



LOW BACKLASH PLANETARY GEARBOXES



RECKON DRIVES INTERNATIONAL S.A.S.
3 rue JC MILLERET - Immeuble Horizon
F-42000 SAINT-ETIENNE
FRANCE

contact@reckondrives.com
www.reckondrives.com





you make
every **second**
count



So we make
every **arc second**
count*

* Reckon offers 1 arc-min backlash
from size 90 mm (depending on the ratio) to size 285 mm

Assuring quality is our professional commitment,
Performance and improvement are our principles,
Customers' full satisfaction is our pride.

RECKON Planetary Gearboxes

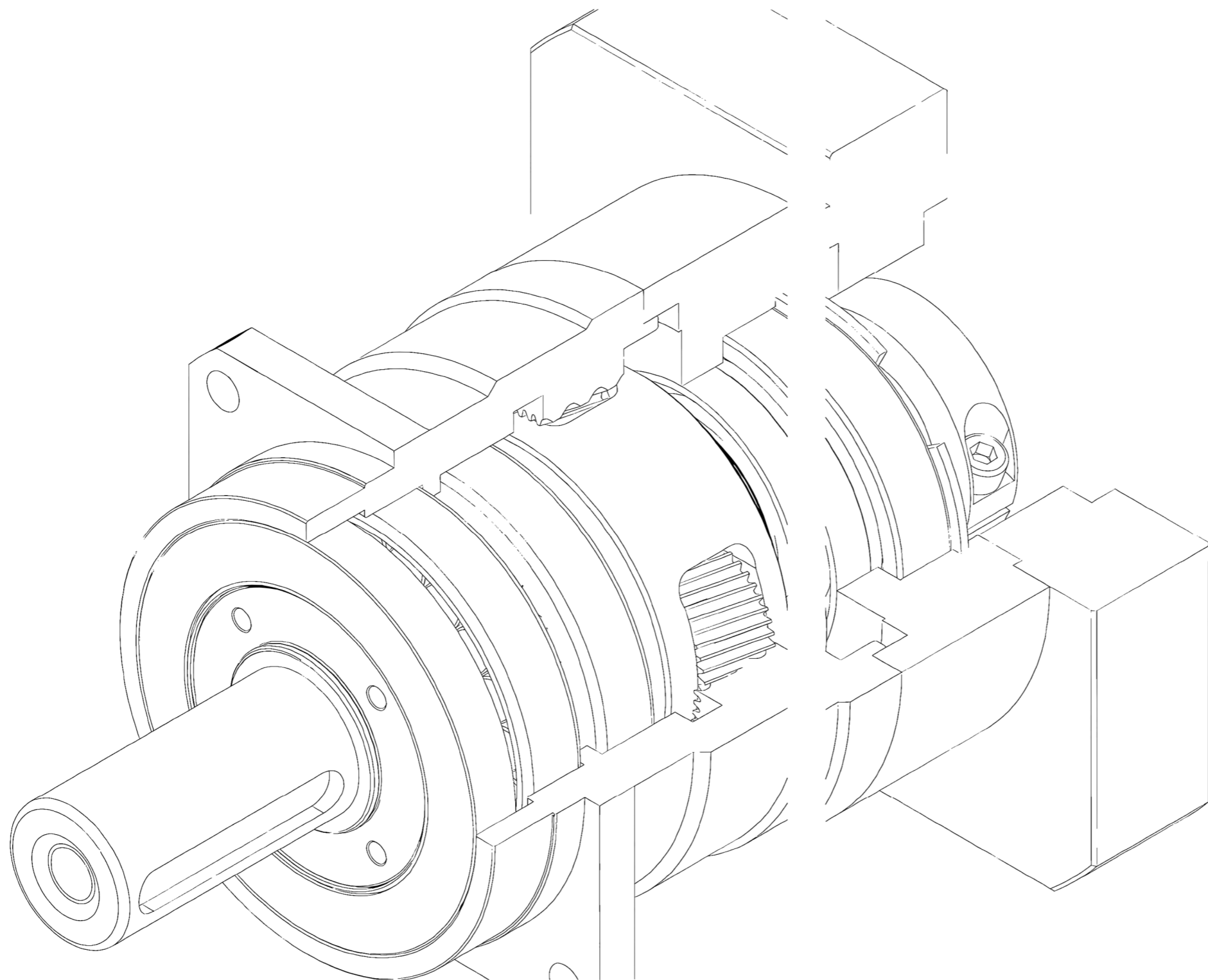

14-19

MKB



20-25

MKE

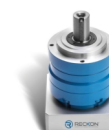

26-31

MKD



32-37

MKF

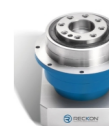

38-43

MKBR



44-49

MKER



50-55

MKDR



56-61

MKFR



How do planetary gearboxes work?

The sun gear (1) rotates together with your motor shaft.

It meshes simultaneously with 3 or more planet gears (2)

The planet gears rotate simultaneously around the sun gear and inside the ring gear (3)

> The reduction ratio between sun gear and planet gears is:

Planet gears' number of teeth (Z2) / Sun gear's number of teeth (Z1)

> The reduction ratio between the planet gears and the ring gear is :

Ring gear's number of teeth (Z3) / planet gears number of teeth (Z2)

The planet gears rotate inside the ring gear the same direction your motor does.

Since they are inserted in the planet carrier (4), the output shaft rotates the same speed the planet gears rotate inside the ring gear.

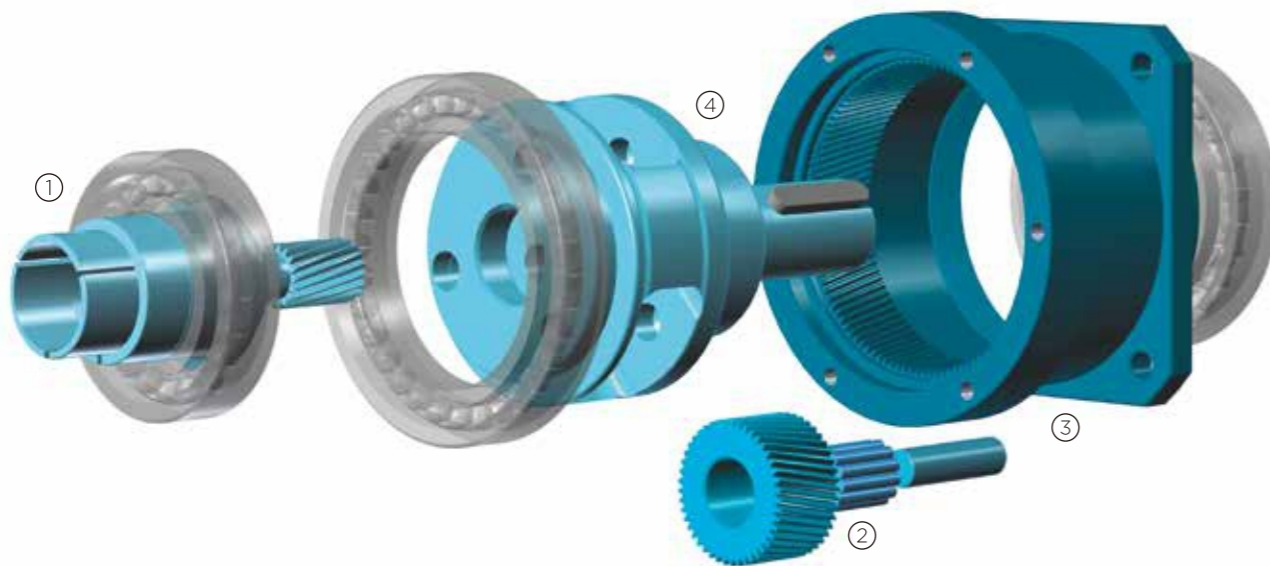

Total reduction ratio between the sun gear and the output shaft is: $1 + Z3/Z1$. It is an exact number, which means the number of rotation of the output shaft is exactly proportional to the number of rotation on the input shaft. However, within one rotation, the angular position of the shaft cannot be considered exact, its precision depends on the precision of the inner elements of the gearbox and is more or less equivalent to the backlash.

Considering the need for a minimal number of teeth on the sun gear, it is generally considered that 1-stage gearboxes should not offer ratios above 10. Planetary gearboxes with ratios above 10 usually pile-up stages, so a ratio 25 gearbox is made of 2 ratio 5 stages.

Quality-based performance

All Reckon[®] planetary gearboxes feature the following elements:



High-precision, carburized, quenched gears.

Offering superior performance, long lifetime and everlasting precision even under tough working conditions.



PerfectPitch™

PerfectPitch™ concept*

Offering silent operation and high reliability to your gearbox.

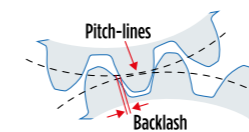

Low backlash

<1 arc-min backlash option available on most 1-stage models size 90 and above.



Balanced input coupling

Offers a strong grip, avoiding vibration and preserving your motor shaft bearings against radial efforts.



Double-supported, caged planet carriers**

Increasing stiffness and improving meshing of the gears during accelerations.



Bearings, seals and lubricants from premium suppliers

We source our components safely from renowned world-class suppliers.

* Available the WISER, LIVELY, BOOSTER and ULTIMATE series.

**Available on all Perfect Pitch™ compliant series.

Product line

Model selection

Performance rating scale

Model	Positioning accuracy	Radial force	Torsional stiffness	Backlash	Wide range of size	Power density	Wide range of ratio
 MKB	MMM	MM	MMM	MMM	MMM	MMM	MMM
 MKE	MMM	MM	MMM	MMM	MMM	MMM	MMM
 MKD	MMM	MMM	MMM	MMM	MM	MMM	MMM
 MKF	MMM	MMM	MMM	MMM	MM	MMM	MM
 MKBR	MMM	MM	MMM	MM	M	MMM	MMM
 MKER	MMM	MM	MMM	MM	M	MMM	MMM
 MKDR	MMM	MMM	MMM	MM	M	MMM	MMM
 MKFR	MMM	MMM	MMM	MM	M	MMM	MMM

M Standard MM Good MMM Maximum

Indication for model selection

Model	Size	Ratio	Precision	Output Shaft	Flange code
MKB	040/060/090/120/140/180/220/240/300	3~100	H:High Precision P:Precision S:Standard	K: Output Shaft With Key S: Smooth Output Shaft	F008
MKE	040/060/090/120/155/205/235/270/330	3~100			
MKD	060/075/100/140/180/210/240	3~100			
MKF	047/064/090/110/140/200/255/258	4~100			
MKBR	040/060/090/120/140/180/220	3~100			
MKER	040/060/090/120/155/205/235	3~100			
MKDR	060/075/100/140/180/210	3~100			
MKFR	047/064/090/110/140/200	4~100			

* 1 Stage (3~10) , 2 Stages (12~100)
 The following two stage transmission ratios are also available
 3x4=12, 3x7=21, 3x9=27, 4x4=16, 4x6=24, 4x7=28

Formula symbols and indices

Designation	Symbol	Unit
Reduction ratio	i	
Nominal output torque	T_{2N}	Nm
Peak acceleration torque	T_{2B}	Nm
Emergency braking torque	T_{2Not}	Nm
Nominal input shaft speed	n_{1N}	rpm
Max.input shaft speed	n_{1Max}	rpm
Backlash	j_t	arcmin
Torsional stiffness	C_{2t}	Nm/arcmin
Max. radial load	F_{2RMax}	N
Max. axial load	F_{2AMax}	N
Rotational inertia	J_1	$kgcm^2$
Working efficiency	η	%
Working lifetime	L_h	h
Operating temperature	T	$^{\circ}C$
Lubrication Method	Lub	
Protection class	PC	
Mounting position	MP	
Noise	dB	

The following table indicates all the symbols and the units that are used in this catalogue. For the 8 gearbox series, all the technical data refer to the present table.

Basic definitions

keyword	Explanation
Arc Minutes	1 degree is equal to 60 arc minutes ($1^{\circ}=60$ arcmin). When the return clearance is 1 arcmin, the angular deviation transmitted to the output end after the gearbox rotates one circle is 1/60 degree.
Return clearance	It refers to the maximum deviation angle generated when the output shaft and input shaft of the reducer rotate. When measuring, first fix the input shaft of the reducer, and then use a torque meter to load a certain torque at the output end to overcome the friction in the gearbox.
Hysteresis curve	The purpose of testing hysteresis is to obtain the torsional stiffness of the reducer. Through testing, the hysteresis curve can be obtained. During the test, the input end of the reducer is fixed first, and then the two rotation directions of the output end are continuously loaded to T_{28} (maximum acceleration torque) and then gradually unloaded. The torsion angle corresponding to the torque can be drawn, and a closed curve can be obtained. The return clearance and torsional stiffness of the reducer can be calculated from the hysteresis curve.
Torsional stiffness	Defined by the ratio between the loading torque and the generated torsion angle, $C_{2t} = \Delta T / \Delta \phi$. On the hysteresis curve, it can be calculated how much torque is needed to rotate the output shaft by one arc minute.
Moment of Inertia	Moment of inertia, in physics, quantitative measure of the rotational inertia of a body—i.e., the opposition that the body exhibits to having its speed of rotation about an axis altered by the application of a torque (turning force).

Return clearance diagram

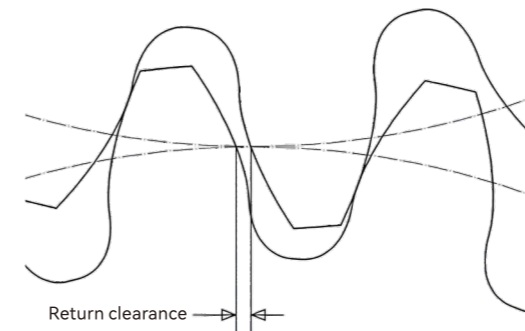

Hysteresis curve diagram

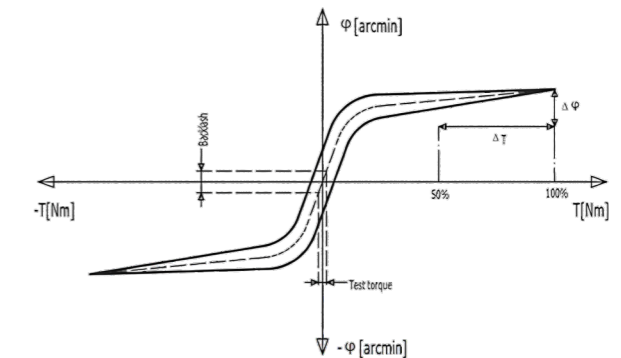

Ordering process

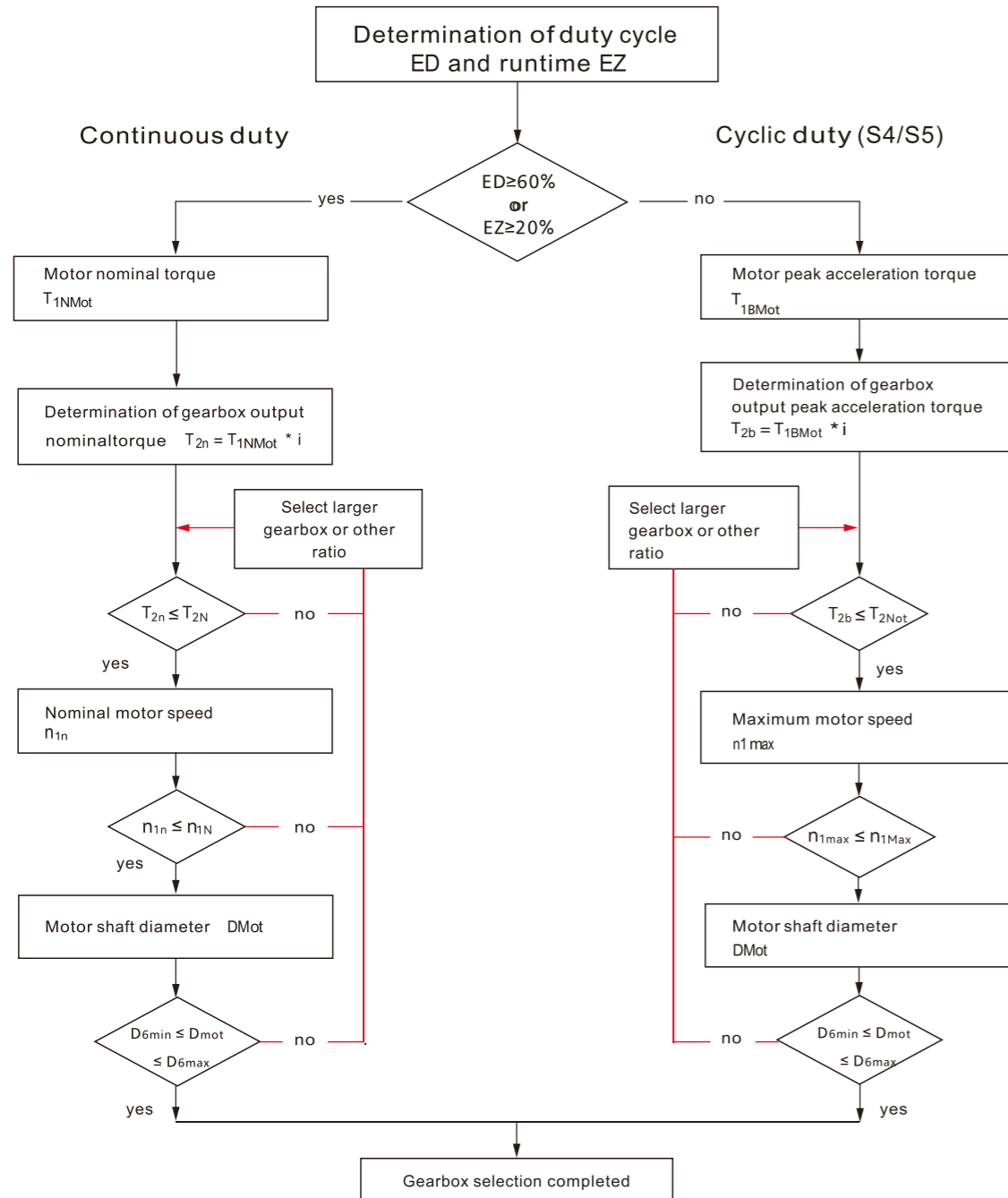

	from catalogue	n, n	nominal motor speed
T2N	from catalogue	n1N	gearbox nominal input speed from catalogue
T2Not	from catalogue	n1max	maximum motor speed
TmMot	motor data	n1Max	gearbox maximum input speed from catalogue
T1NMot	motor data		

MKB SERIES



Powerful, robust and precise, this planetary gearbox is designed to work under heavy operating duty.

MKB

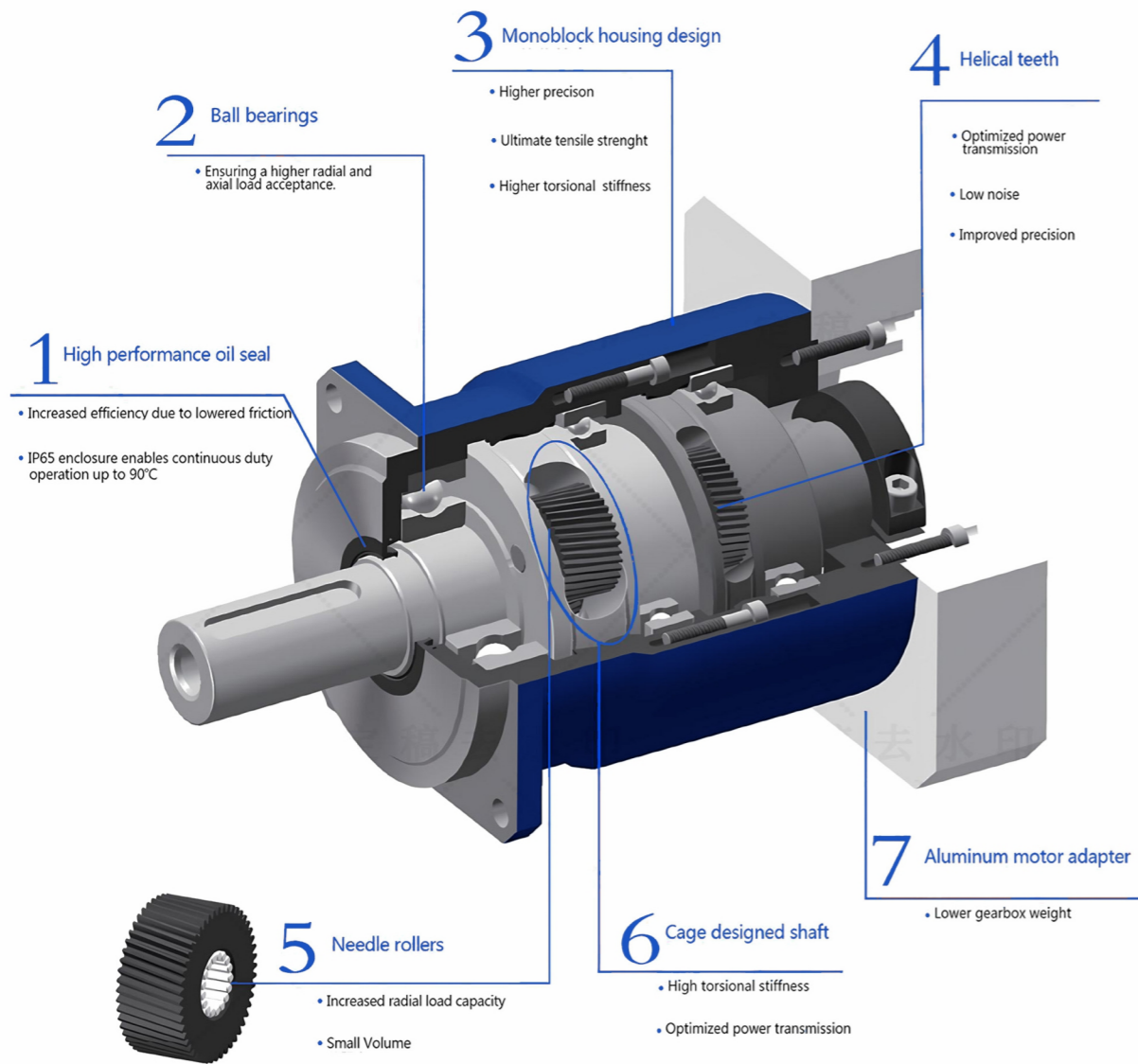

Selection data:

Nominal output torque (Nm)	14-8730
Reduction ratio	3-100
Backlash (arcmin)	1-7
Max.working temperature (°C)	90
Noise (dB)	56-74

specification	series	Ratio	MKB-040	MKB-060	MKB-090	MKB-120	MKB-140	MKB-180	MKB-220	MKB-240	MKB-300	
Rated output torque T_{2N}	1	3	20	55	130	240	350	600	1100	3000	8450	
		4	19	50	140	320	550	1000	1700	3000	8730	
		5	22	60	160	360	650	1200	2000	3150	8660	
		6	20	55	150	350	600	1100	1900	3150	8520	
		7	20	55	150	360	600	1100	1800	3150	8520	
		8	20	55	140	360	550	1000	1800	3000	8390	
		9	14	40	100	230	450	900	1500	2400	8310	
		10	14	40	100	230	450	900	1500	2400	8310	
		2	15	20	55	130	240	460	980	1300	3000	8150
			20	19	50	140	320	650	1350	1800	3000	8730
	25		22	60	160	330	650	1200	2000	3150	8660	
	30		20	55	150	310	650	1100	1900	3000	8520	
	35		20	60	150	360	550	1400	1900	3000	8520	
	40		20	55	150	260	500	1000	1600	2800	8440	
	45		14	40	100	230	450	900	1500	2700	8300	
	50		22	60	160	360	700	1400	2000	3150	8660	
	60		20	55	150	310	600	1100	1900	3000	8520	
	70		19	50	140	300	550	1100	1800	2900	8520	
	80	20	55	140	360	700	1400	1900	3150	8600		
	90	14	40	100	230	460	980	1500	2300	8310		
100	14	40	100	230	460	980	1500	2300	8310			
Maximum output torque T_{2M}	Nm	1, 2	3~100	3 times the rated output torque								
Rated input speed n_{1N}	rpm	1, 2	3~100	5000	5000	4000	4000	3000	3000	2000	2000	1500
Maximum input speed n_{2M}	rpm	1, 2	3~100	10000	10000	8000	8000	6000	6000	4000	4000	3000
Backlash accuracy_H (high precision)	arcmin	1	3~10	-	-	≤1	≤1	≤1	≤1	≤1	≤1	≤1
		2	15~100	-	-	≤3	≤3	≤3	≤3	≤3	≤3	≤3
Backlash accuracy_P (precision)	arcmin	1	3~10	≤3	≤3	≤3	≤3	≤3	≤3	≤3	≤3	≤3
		2	15~100	≤5	≤5	≤5	≤5	≤5	≤5	≤5	≤5	≤5
Backlash accuracy_S (standard)	arcmin	1	3~10	≤5	≤5	≤5	≤5	≤5	≤5	≤5	≤5	≤5
		2	15~100	≤7	≤7	≤7	≤7	≤7	≤7	≤7	≤7	≤7
Torsional rigidity	Nm/arcmin	1, 2	3~100	3	8	20	41	50	145	225	540	980
Allowable radial force F_{2R}	N	1, 2	3~100	780	1500	3200	6700	9400	14500	50000	85000	224500
Allowable axial force F_{2A}	N	1, 2	3~100	610	1050	2300	4100	8300	13500	25000	56500	112000
working life	hr	1, 2	3~100	20000h								
efficiency η	%	1	3~10	≥97%								
		2	15~100	≥94%								
weight	kg	1	3~100	0.8	1.5	2.6	6.6	15.5	29	48	105	190
		2	15~100	1.3	2	4	9	17	33	60	120	220
Operating temperature	°C	1, 2	3~100	-15°C~+90°C								
lubrication		1, 2	3~100	IP65								
Ingress protection		1, 2	3~100	Life Lubricated								
Mounting direction		1, 2	3~100	Any								
Noise level(n_t=3000rpm)	dB	1, 2	3~100	≤56	≤58	≤60	≤63	≤65	≤67	≤70	≤72	≤74

specification	series	Ratio	MKB-040	MKB-060	MKB-090	MKB-120	MKB-140	MKB-180	MKB-220	MKB-240	MKB-300	
Inertia J₁	1	3	0.03	0.16	0.61	3.25	9.21	28.98	69.61	185.05	252.96	
		4	0.03	0.14	0.48	2.74	7.54	23.67	54.37	183.43	230.72	
		5	0.03	0.13	0.47	2.71	7.42	23.29	53.27	183.43	226.29	
		6	0.03	0.13	0.45	2.65	7.25	22.75	51.72	183.43	226.29	
		7	0.03	0.13	0.45	2.62	7.14	22.48	50.97	183.43	216.29	
		8	0.03	0.13	0.44	2.58	7.07	22.59	50.84	183.43	216.29	
		9	0.03	0.13	0.44	2.57	7.04	22.53	50.63	177.26	216.29	
		10	0.03	0.13	0.44	2.57	7.03	22.51	50.56	175.39	214.55	
		2	15	0.03	0.03	0.13	0.47	2.71	7.42	23.29	53.27	183.43
			20	0.03	0.03	0.13	0.47	2.71	7.42	23.29	53.27	183.43
	25		0.03	0.03	0.13	0.47	2.71	7.42	23.29	53.27	183.43	
	30		0.03	0.03	0.13	0.47	2.71	7.42	23.29	53.27	183.43	
	35		0.03	0.03	0.13	0.47	2.71	7.42	23.29	53.27	183.43	
	40		0.03	0.03	0.13	0.47	2.71	7.42	23.29	53.27	183.43	
	45		0.03	0.03	0.13	0.47	2.71	7.42	23.29	53.27	183.43	
	50		0.03	0.03	0.13	0.44	2.57	7.03	22.51	50.56	175.39	
	60		0.03	0.03	0.13	0.44	2.57	7.03	22.51	50.56	175.39	
	70		0.03	0.03	0.13	0.44	2.57	7.03	22.51	50.56	175.39	
	80	0.03	0.03	0.13	0.44	2.57	7.03	22.51	50.56	175.39		
	90	0.03	0.03	0.13	0.44	2.57	7.03	22.51	50.56	175.39		
100	0.03	0.03	0.13	0.44	2.57	7.03	22.51	50.56	175.39			

The output speed of F_{2R} and F_{2A} is 100 rpm, acting at the center of the output shaft.

MKB Series

1-Stage :3,4,5,6,7,8,9,10

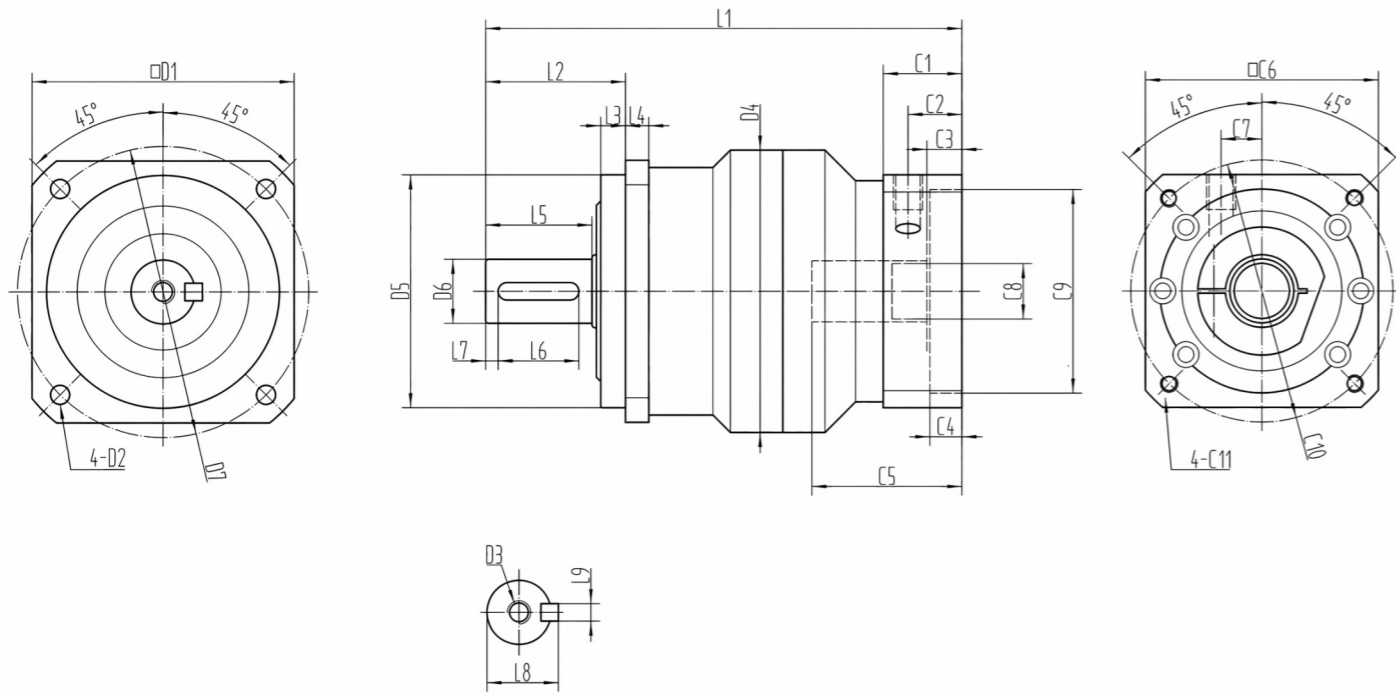

	MKB-040	MKB-060	MKB-090	MKB-120	MKB-140	MKB-180	MKB-220	MKB-240	MKB-300
L1*	89.5	118	163.5	209.5	259	312.5	320	457	504.5
L2	24.5	37	48	65	97	105	138	149	159
L3	4	7	8.5	12	12	20	30	14	14
L4	4	8	8	12	12	15	20	24	28
L5	19.5	28.5	36.5	49.5	82	82	105	130	140
L6	15	25	32	40	65	70	90	125	120
L7	2	2	2	5	5	6	7	3	10
L8	15	18	24.5	35	43	59	79.5	90	106
L9	5	5	6	10	12	16	20	22	28
D1	42	60	90	115	140	180	220	270	342
D2	3.4	5.5	6.6	9	11	13.5	17	17	22
D3	M4*10	M5*12	M8*20	M12*28	M16*36	M20*42	M20*42	M20*42	M24*42
D4	42	65	97	124	150	200	225	270	342
D5	35	50	80	110	130	160	180	200	250
D6	13	16	22	32	40	55	75	85	100
D7	50	70	100	130	165	215	250	300	380
C1*	17.5	23	27	37.5	47	76	50	96	96
C2*	11.5	16	18.5	26	26	55	29	63	63
C3*	7	11	12	19.5	18.5	45	19	48.5	51
C4*	3.5	10.5	11	10	8	10	10	10	10
C5*	29.5	37	51.5	70	81.5	114	88	145	147.5
C6*	42	60	80	130	176	180	200	280	280
C7*	6.5	10.5	14	20	27	30	30	40	40
C8*	8	14	19	24	35	42	38	55	55
C9*	30	50	70	110	114.3	114.3	180	250	250
C10*	46	70	90	145	200	200	215	300	300
C11*	M4*8	M5*10	M6*12	M8*16	M12*25	M12*30	M12*24	M16*32	M16*32

The one with * is a reference, and the size can be adjusted.

MKB Series

2-Stage :15,20,25,30,35,40,45,50,60,70,80,90,100

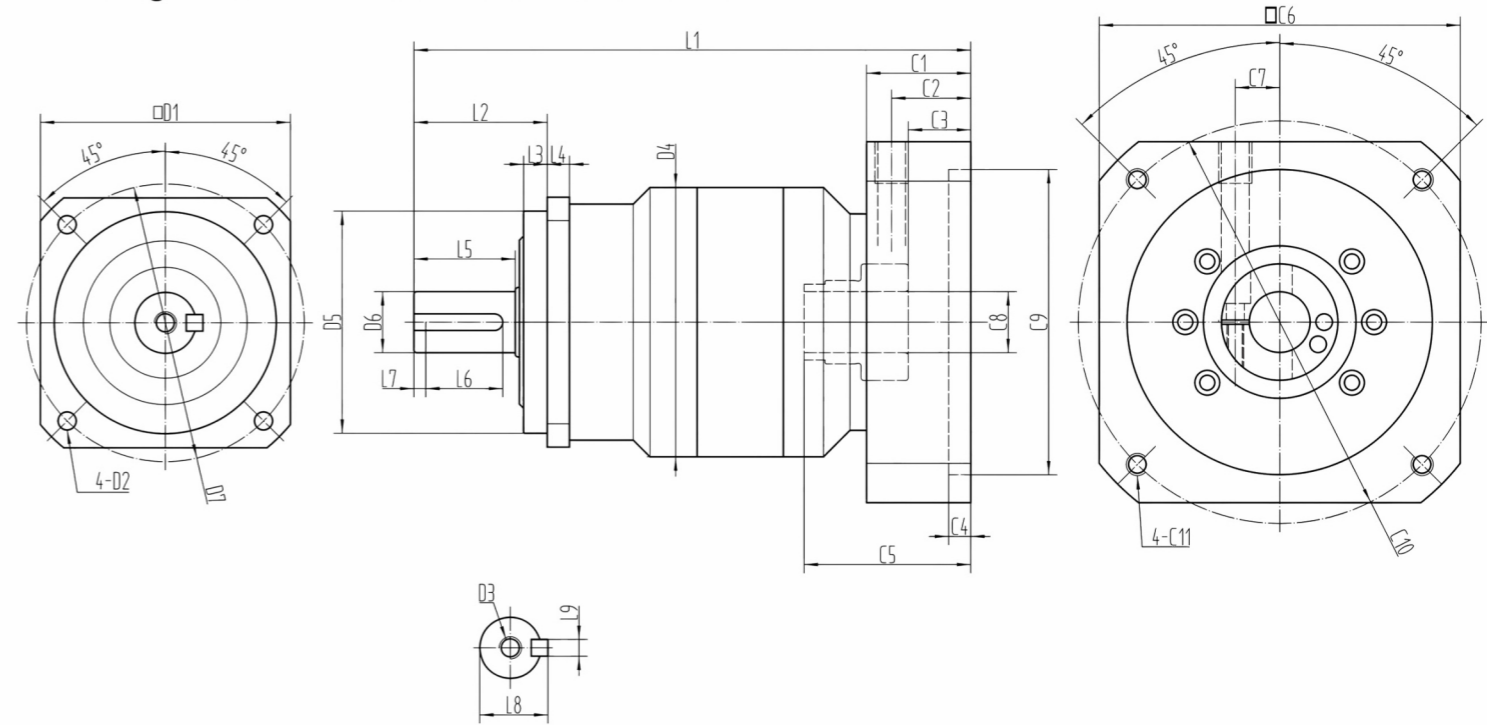

	MKB-040	MKB-060	MKB-090	MKB-120	MKB-140	MKB-180	MKB-220	MKB-240
L1*	106.5	138	190	246.5	310	338.5	397	516
L2	24.5	37	48	65	97	105	138	149
L3	4	7	8.5	12	12	20	30	14
L4	4	8	8	12	12	15	20	24
L5	19.5	28.5	36.5	49.5	82	82	105	130
L6	15	25	32	40	65	70	90	125
L7	2	2	2	5	5	6	7	3
L8	15	18	24.5	35	43	59	79.5	90
L9	5	5	6	10	12	16	20	22
D1	42	60	90	115	140	180	220	270
D2	3.4	5.5	6.6	9	11	13.5	17	17
D3	M4*10	M5*12	M8*20	M12*28	M16*36	M20*42	M20*42	M20*42
D4	42	65	97	124	150	200	225	270
D5	35	50	80	110	130	160	180	200
D6	13	16	22	32	40	55	75	85
D7	50	70	100	130	165	215	250	300
C1*	17.5	23	27	37.5	47	50	72	96
C2*	11.5	16	18.5	26	26	29	58	63
C3*	7	11	12	20	18	19	48	51
C4*	3.5	10.5	11	10	8	10	10	10
C5*	29.5	37	49.5	71.5	85	88	117	145.5
C6*	42	60	80	130	176	200	220	280
C7*	6.5	10.5	14	20	27	30	35	40
C8*	8	14	19	24	35	38	55	55
C9*	30	50	70	110	114.3	180	200	250
C10*	46	70	90	145	200	215	235	300
C11*	M4*8	M5*12	M6*12	M8*16	M12*25	M12*24	M12*24	M16*36

The one with * is a reference, and the size can be adjusted.

MKB Series

2-Stage(Smaller type) :15,20,25,30,35,40,45,50,60,70,80,90,100

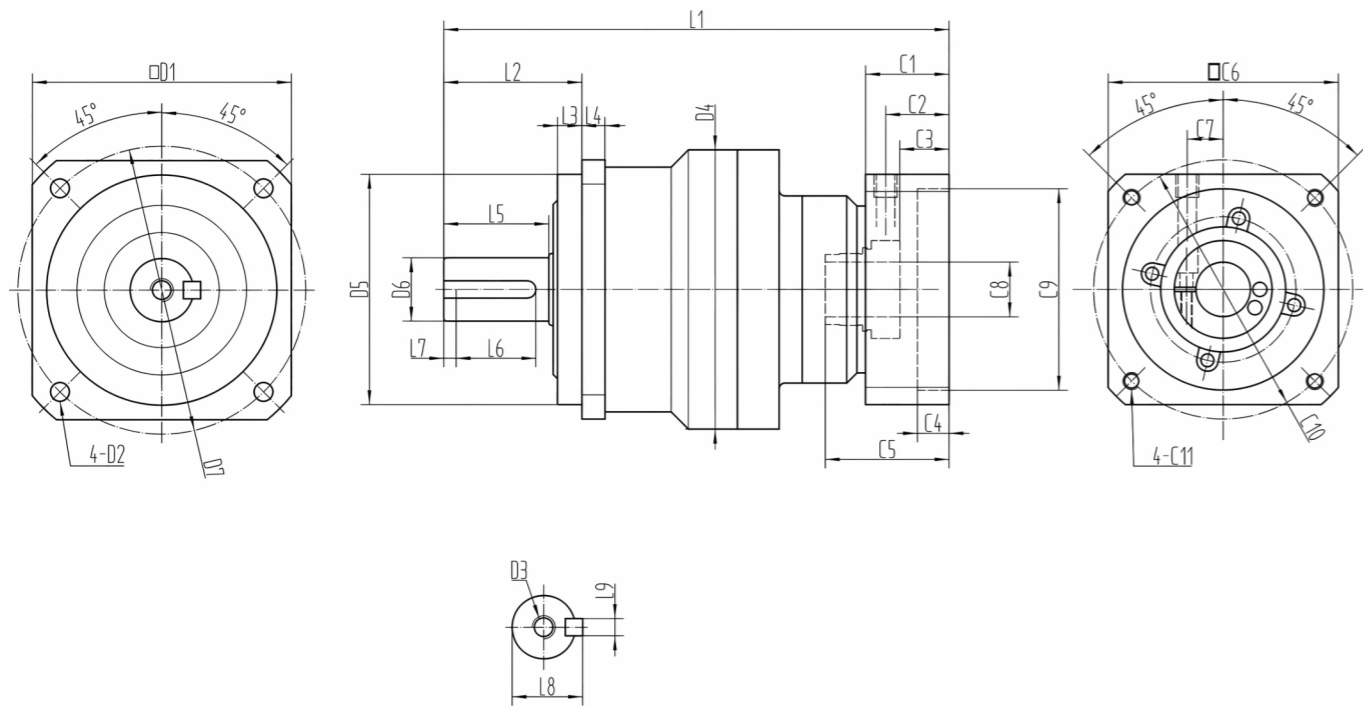

	MKB-090	MKB-120	MKB-140	MKB-180	MKB-220	MKB-240
L1*	169.5	214.5	284	327	397	459.5
L2	48	65	97	105	138	149
L3	8.5	12	12	20	30	14
L4	8	12	12	15	20	24
L5	36.5	49.5	82	82	105	130
L6	32	40	65	70	90	125
L7	2	5	5	6	7	3
L8	24.5	35	43	59	79.5	90
L9	6	10	12	16	20	22
D1	90	115	140	180	220	270
D2	6.6	9	11	13.5	17	17
D3	M8*20	M12*28	M16*36	M20*42	M20*42	M20*42
D4	97	124	150	200	225	270
D5	80	110	130	160	180	200
D6	22	32	40	55	75	85
D7	100	130	165	215	250	300
C1*	23	27	37.5	47	79	50
C2*	16	18.5	26	26	58	29
C3*	11	12	20	18	48	19
C4*	10.5	11	10	8	10	10
C5*	37	49.5	71.5	85	117	88
C6*	60	80	130	176	176	220
C7*	10.5	14	20	27	30	30
C8*	14	19	24	35	42	38
C9*	50	70	110	114.3	114.3	180
C10*	70	90	145	200	200	215
C10*	M5*10	M6*12	M8*15	M12*24	M12*24	M12*24

The one with * is a reference, and the size can be adjusted.



MKE SERIES



Powerful, robust and precise, this planetary gearbox is designed to work under heavy operating duty.

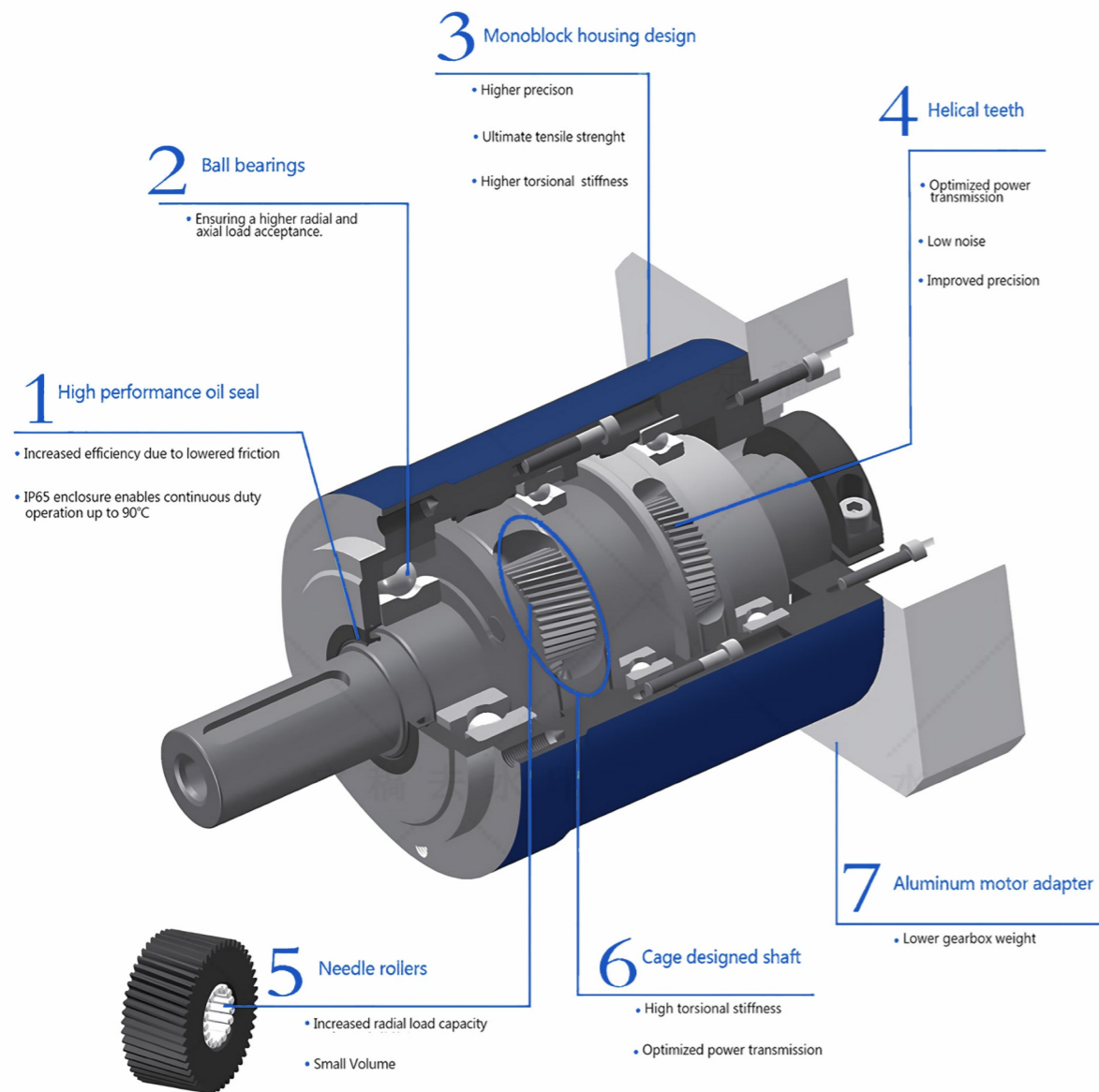

MKE

Selection data:

Nominal output torque (Nm)	14-8730
Reduction ratio	3-100
Backlash (arcmin)	1-7
Max.working temperature (°C)	90
Noise (dB)	56-74

specification	series	Ratio	MKE-040	MKE-060	MKE-090	MKE-120	MKE-155	MKE-205	MKE-235	MKE-270	MKE-330	
Rated output torque T_{2N}	1	3	20	55	130	240	350	600	1100	3000	8450	
		4	19	50	140	320	550	1000	1700	3000	8730	
		5	22	60	160	360	650	1200	2000	3150	8660	
		6	20	55	150	350	600	1100	1900	3150	8520	
		7	20	55	150	360	600	1100	1800	3150	8520	
		8	20	55	140	360	550	1000	1800	3000	8390	
		9	14	40	100	230	450	900	1500	2400	8310	
		10	14	40	100	230	450	900	1500	2400	8310	
		2	15	20	55	130	240	460	980	1300	3000	8150
			20	19	50	140	320	650	1350	1800	3000	8730
	25		22	60	160	330	650	1200	2000	3150	8660	
	30		20	55	150	310	650	1100	1900	3000	8520	
	35		20	60	150	360	550	1400	1900	3000	8520	
	40		20	55	150	260	500	1000	1600	2800	8440	
	45		14	40	100	230	450	900	1500	2700	8300	
	50		22	60	160	360	700	1400	2000	3150	8660	
	60		20	55	150	310	600	1100	1900	3000	8520	
	70		19	50	140	300	550	1100	1800	2900	8520	
	80	20	55	140	360	700	1400	1900	3150	8600		
	90	14	40	100	230	460	980	1500	2300	8310		
100	14	40	100	230	460	980	1500	2300	8310			
Maximum output torque T_{2M}	Nm	1, 2	3 times the rated output torque									
Rated input speed n_{1N}	rpm	1, 2	3~100	5000	5000	4000	4000	3000	3000	2000	2000	1500
Maximum input speed n_{2M}	rpm	1, 2	3~100	10000	10000	8000	8000	6000	6000	4000	4000	3000
Backlash accuracy_H (high precision)	arcmin	1	3~10	-	-	≤1	≤1	≤1	≤1	≤1	≤1	≤1
		2	15~100	-	-	≤3	≤3	≤3	≤3	≤3	≤3	≤3
Backlash accuracy_P (precision)	arcmin	1	3~10	≤3	≤3	≤3	≤3	≤3	≤3	≤3	≤3	≤3
		2	15~100	≤5	≤5	≤5	≤5	≤5	≤5	≤5	≤5	≤5
Backlash accuracy_S (standard)	arcmin	1	3~10	≤5	≤5	≤5	≤5	≤5	≤5	≤5	≤5	≤5
		2	15~100	≤7	≤7	≤7	≤7	≤7	≤7	≤7	≤7	≤7
Torsional rigidity	Nm/arcmin	1, 2	3~100	3	8	20	41	50	145	225	540	980
Allowable radial force F_{2R}	N	1, 2	3~100	780	1500	3200	6700	9400	14500	50000	85000	224500
Allowable axial force F_{2A}	N	1, 2	3~100	610	1050	2300	4100	8300	13500	25000	56500	112000
working life	hr	1, 2	3~100	20000h								
efficiency η	%	1	3~10	≥97%								
		2	15~100	≥94%								
weight	kg	1	3~100	0.8	1.5	2.6	6.6	15.5	29	48	105	190
		2	15~100	1.3	2	4	9	17	33	60	120	220
Operating temperature	°C	1, 2	3~100	-15°C~+90°C								
lubrication		1, 2	3~100	IP65								
Ingress protection		1, 2	3~100	Life Lubricated								
Mounting direction		1, 2	3~100	Any								
Noise level ($n_t=3000rpm$)	dB	1, 2	3~100	≤56	≤58	≤60	≤63	≤65	≤67	≤70	≤72	≤74

specification	series	Ratio	MKE-040	MKE-060	MKE-090	MKE-120	MKE-155	MKE-205	MKE-235	MKE-270	MKE-330	
Inertia J_1	1	3	0.03	0.16	0.61	3.25	9.21	28.98	69.61	185.05	252.96	
		4	0.03	0.14	0.48	2.74	7.54	23.67	54.37	183.43	230.72	
		5	0.03	0.13	0.47	2.71	7.42	23.29	53.27	183.43	226.29	
		6	0.03	0.13	0.45	2.65	7.25	22.75	51.72	183.43	226.29	
		7	0.03	0.13	0.45	2.62	7.14	22.48	50.97	183.43	216.29	
		8	0.03	0.13	0.44	2.58	7.07	22.59	50.84	183.43	216.29	
		9	0.03	0.13	0.44	2.57	7.04	22.53	50.63	177.26	216.29	
		10	0.03	0.13	0.44	2.57	7.03	22.51	50.56	175.39	214.55	
		2	15	0.03	0.03	0.13	0.47	2.71	7.42	23.29	53.27	183.43
			20	0.03	0.03	0.13	0.47	2.71	7.42	23.29	53.27	183.43
	25		0.03	0.03	0.13	0.47	2.71	7.42	23.29	53.27	183.43	
	30		0.03	0.03	0.13	0.47	2.71	7.42	23.29	53.27	183.43	
	35		0.03	0.03	0.13	0.47	2.71	7.42	23.29	53.27	183.43	
	40		0.03	0.03	0.13	0.47	2.71	7.42	23.29	53.27	183.43	
	45		0.03	0.03	0.13	0.47	2.71	7.42	23.29	53.27	183.43	
	50		0.03	0.03	0.13	0.44	2.57	7.03	22.51	50.56	175.39	
	60		0.03	0.03	0.13	0.44	2.57	7.03	22.51	50.56	175.39	
	70		0.03	0.03	0.13	0.44	2.57	7.03	22.51	50.56	175.39	
	80	0.03	0.03	0.13	0.44	2.57	7.03	22.51	50.56	175.39		
	90	0.03	0.03	0.13	0.44	2.57	7.03	22.51	50.56	175.39		
100	0.03	0.03	0.13	0.44	2.57	7.03	22.51	50.56	175.39			

The output speed of F_{2R} and F_{2A} is 100 rpm, acting at the center of the output shaft.

MKE Series

1-Stage(Smaller type) :3,4,5,6,7,8,9,10

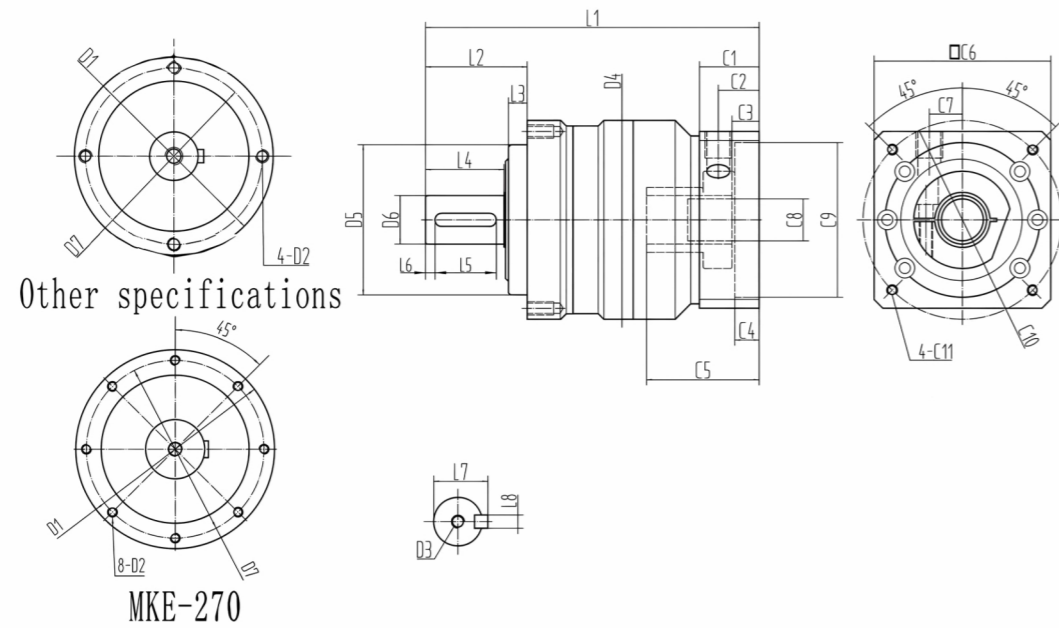

MKE-270

	MKE-040	MKE-060	MKE-090	MKE-120	MKE-155	MKE-205	MKE-235	MKE-270
L1*	89.5	118	151	201.5	259	312.5	320	457
L2	24.5	36.5	46	68.5	97	100	126	173
L3	4	6.5	8.5	17.5	12	15	18	38
L4	19.5	28.5	35.5	49.5	82	82	105	130
L5	15	25	32	40	65	70	90	125
L6	2	2	2	5	5	6	7	3
L7	13.5	18	24.5	35	43	59	79.5	90
L8	4	5	6	10	12	16	20	22
D1	50	70	90	120	155	205	235	270
D2	M4*8	M5*10	M6*12	M8*16	M10*20	M12*24	M16*28	M12*24
D3	M4*10	M5*13	M8*20	M12*28	M16*36	M20*42	M20*42	M20*42
D4	46	65	90	122	150	200	225	265
D5	35	52	68	90	120	160	180	200
D6	12	16	22	32	40	55	75	85
D7	44	62	80	108	140	184	210	240
C1*	17.5	23	27	37.5	47	76	50	96
C2*	11.5	16	18.5	26	26	55	29	63
C3*	7	11	12	20.5	18.5	45	19	48.5
C4*	3.5	10.5	11	10	8	10	10	10
C5*	29.5	32	51	72	81.5	114	88	145
C6*	42	60	80	130	176	180	200	280
C7*	6.5	10.5	14	20	27	30	30	40
C8*	8	14	19	24	35	42	38	55
C9*	30	50	70	110	114.3	114.3	180	250
C10*	46	70	90	145	200	200	215	300
C11*	M4*8	M5*10	M6*12	M8*15	M12*25	M12*25	M12*24	M16*32

The one with * is a reference, and the size can be adjusted.

MKE Series

2-Stage :15,20,25,30,35,40,45,50,60,70,80,90,100

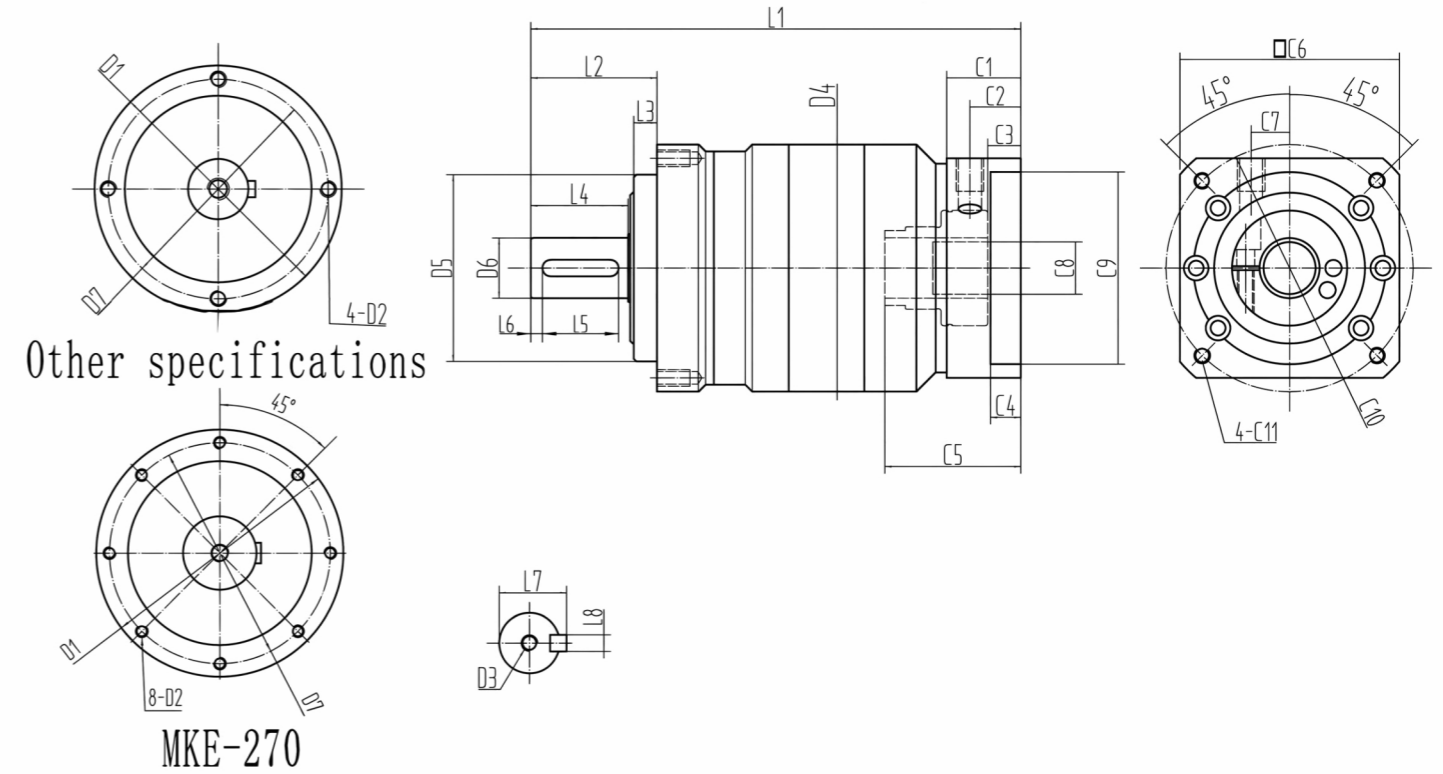

MKE-270

	MKE-040	MKE-060	MKE-090	MKE-120	MKE-155	MKE-205	MKE-235	MKE-270
L1*	106.5	138	178.5	235	310	338.5	397	516
L2	24.5	36.5	46	68.5	97	100	126	173
L3	4	6.5	8.5	17	12	15	18	38
L4	19.5	28.5	35.5	49.5	82	82	105	130
L5	15	25	32	40	65	70	90	125
L6	2	2	2	5	5	6	7	3
L7	13.5	18	24.5	35	43	59	79.5	90
L8	4	5	6	10	12	16	20	22
D1	50	70	90	120	155	205	235	270
D2	M4*8	M5*10	M6*12	M8*16	M10*20	M12*24	M16*28	M12*24
D3	M4*10	M5*13	M8*20	M12*28	M16*36	M20*42	M20*42	M20*42
D4	46	65	90	122	150	200	225	265
D5	35	52	68	90	120	160	180	200
D6	12	16	22	32	40	55	75	85
D7	44	62	80	108	140	184	210	240
C1*	17.5	23	27	37.5	47	50	72	96
C2*	11.5	16	18.5	26	26	29	58	63
C3*	7	11	12	20	18	19	48	51
C4*	3.5	10.5	11	10	8	10	10	10
C5*	29.5	37	49.5	71.5	85	88	117	145.5
C6*	42	60	80	130	176	200	220	280
C7*	6.5	10.5	14	20	27	30	35	40
C8*	8	14	19	24	35	38	55	55
C9*	30	50	70	110	114.3	180	200	250
C10*	46	70	90	145	200	215	235	300
C11*	M4*8	M5*10	M6*12	M8*16	M12*25	M12*24	M12*24	M16*36

The one with * is a reference, and the size can be adjusted.

MKE Series

2-Stage(Smaller type) :15,20,25,30,35,40,45,50,60,70,80,90,100

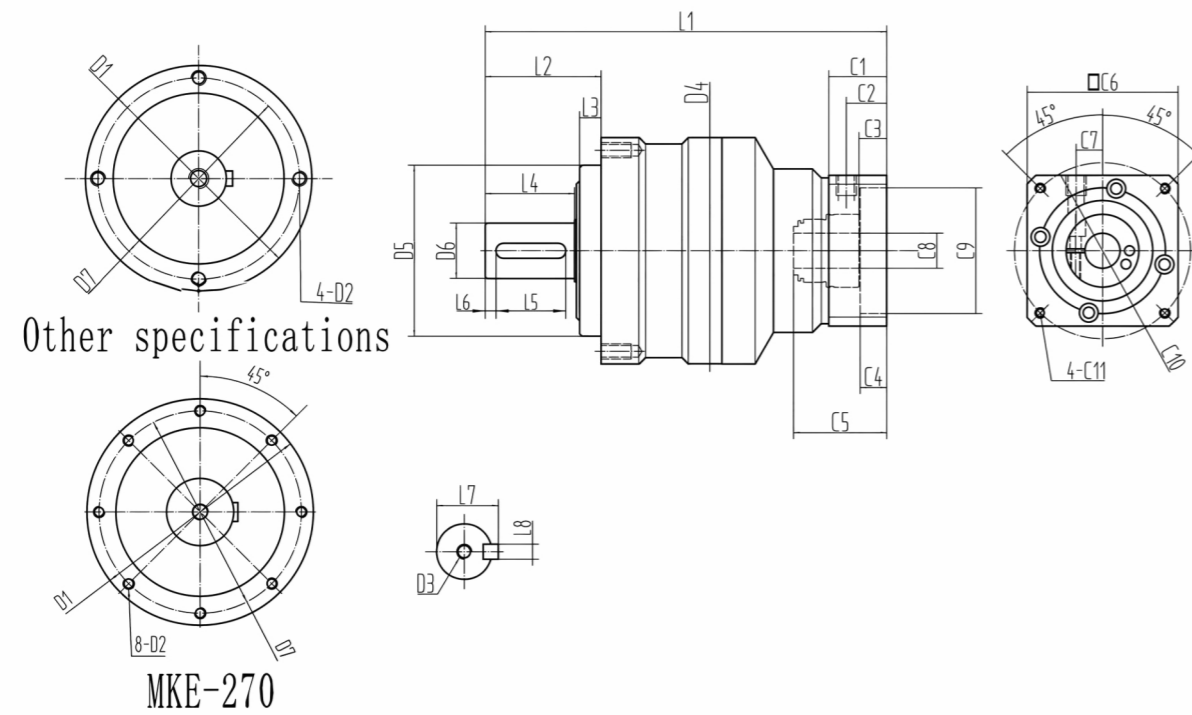

	MKE-090	MKE-120	MKE-155	MKE-205	MKE-235	MKE-270
L1*	159.5	203.5	284	327	394	459.5
L2	46	68.5	97	100	126	173
L3	8.5	17.5	12	15	18	38
L4	35.5	49.5	82	82	105	130
L5	32	40	65	70	90	125
L6	2	5	5	6	7	3
L7	24.5	35	43	59	79.5	90
L8	6	10	12	16	20	22
D1	90	120	155	205	235	270
D2	M6*12	M8*16	M10*20	M12*24	M16*28	M12*24
D3	M8*20	M12*28	M16*36	M20*42	M20*42	M20*42
D4	90	122	150	200	225	265
D5	68	90	120	160	180	200
D6	22	32	40	55	75	85
D7	80	108	140	184	210	240
C1*	23	27	37.5	47	76	50
C2*	16	18.5	26	26	55	29
C3*	11	12	21	18	45	19
C4*	10.5	11	10	8	10	10
C5*	37	49.5	72.5	85	114	88
C6*	60	80	130	176	180	220
C7*	10.5	14	20	27	30	30
C8*	14	19	24	35	42	38
C9*	50	70	110	114.3	114.3	180
C10*	70	90	145	200	200	215
C11*	M5*12	M6*12	M8*15	M12*25	M12*24	M12*24

The one with * is a reference, and the size can be adjusted.



MKD SERIES



The MKD high-end series symbolize optimum precision, maximum torque and resistance to radial & axial loads.

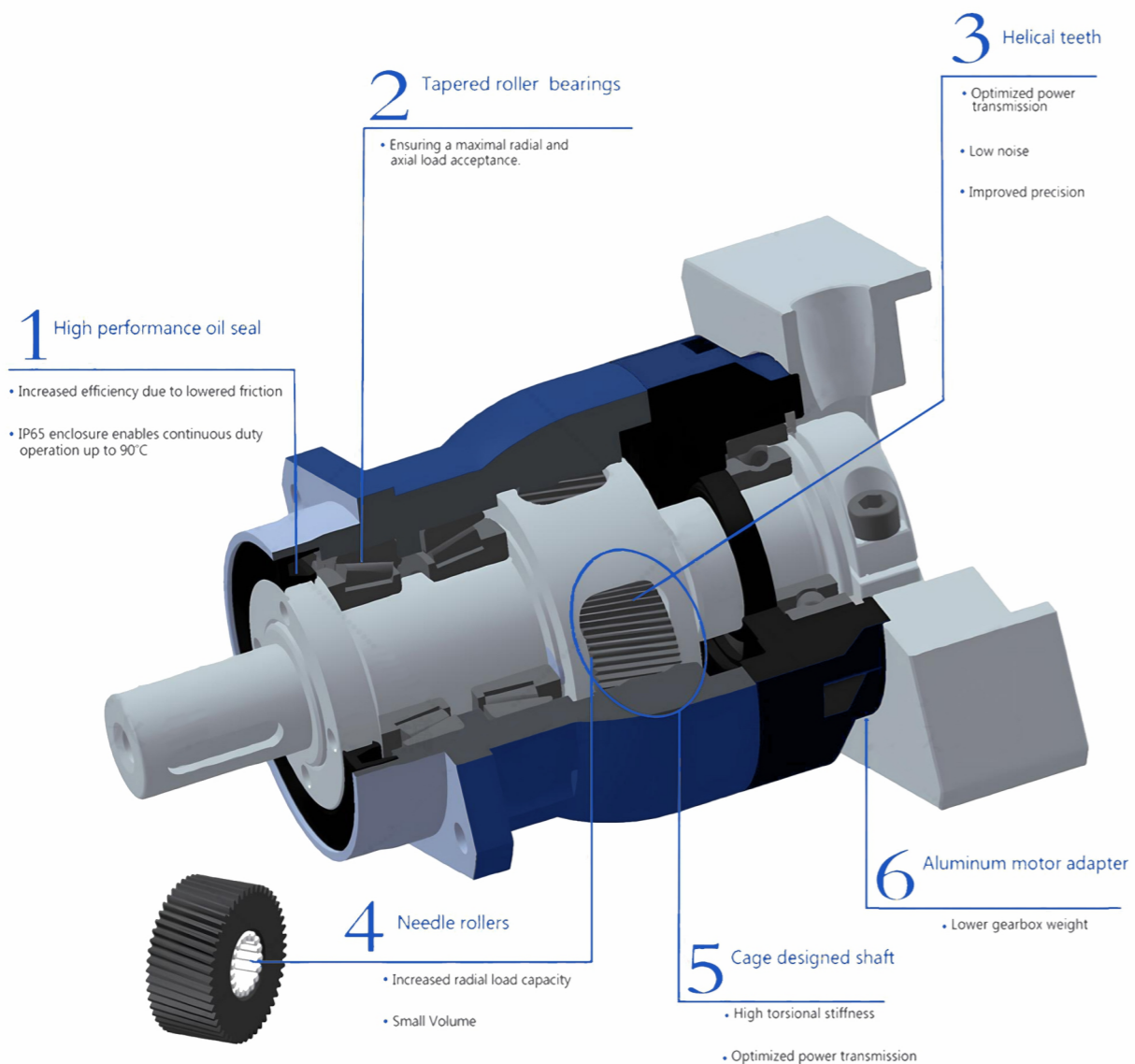

MKD

Selection data:

Nominal output torque (Nm)	40-3150
Reduction ratio	3-100
Backlash (arcmin)	1-7
Max.working temperature (°C)	90
Noise (dB)	58-72

specification	series	Ratio	MKD-060	MKD-075	MKD-100	MKD-140	MKD-180	MKD-210	MKD-240			
Rated output torque T_{2N}	1	3	55	130	240	350	1100	2000	3000			
		4	50	140	320	550	1700	2100	3000			
		5	60	160	360	650	2000	2200	3150			
		6	55	150	350	600	1900	2200	3150			
		7	55	150	360	600	1800	2200	3150			
		8	55	140	360	550	1800	2200	3000			
		9	40	100	230	450	1500	2000	2400			
		10	40	100	230	450	1500	2000	2400			
		2	15	55	130	240	460	1300	2400	3000		
			20	50	140	320	650	1800	2400	3000		
	25		60	160	330	650	2000	2550	3150			
	30		55	150	310	650	1900	2500	3000			
	35		60	150	360	550	1900	2500	3000			
	40		55	150	260	500	1600	2000	2800			
	45		40	100	230	450	1500	2000	2700			
	50		60	160	360	700	2000	2550	3150			
	60		55	150	310	600	1900	2500	3000			
	Maximum output torque T_{2M}	Nm	70	50	140	300	550	1800	2500	2900		
			80	55	140	360	700	1900	2550	3150		
90			40	100	230	460	1500	2000	2300			
100			40	100	230	460	1500	2000	2300			
Maximum input speed n_{1N}			rpm	1, 2	3~100	5000	4000	4000	3000	3000	2000	2000
Maximum input speed n_{2M}			rpm	1, 2	3~100	10000	8000	8000	6000	6000	4000	4000
Backlash accuracy_H (high precision)			arcmin	1	3~10	-	≤1	≤1	≤1	≤1	≤1	≤1
				2	15~100	-	≤3	≤3	≤3	≤3	≤3	≤3
Backlash accuracy_P (precision)			arcmin	1	3~10	≤3	≤3	≤3	≤3	≤3	≤3	≤3
				2	15~100	≤5	≤5	≤5	≤5	≤5	≤5	≤5
Backlash accuracy_S (standard)	arcmin	1	3~10	≤5	≤5	≤5	≤5	≤5	≤5	≤5		
		2	15~100	≤7	≤7	≤7	≤7	≤7	≤7	≤7		
Torsional rigidity	Nm/arcmin	1, 2	3~100	7	14	31	53	175	400	540		
Allowable radial force F_{2R}	N	1, 2	3~100	3000	4200	9200	14000	18500	33000	44000		
Allowable axial force F_{2A}	N	1, 2	3~100	2700	3900	6200	11400	19500	21000	37000		
working life	hr	1, 2	3~100	20000h								
efficiency η	%	1	3~10	≥97%								
		2	15~100	≥94%								
weight	kg	1	3~100	2.1	4	12.5	24	40	72.5	105		
		2	15~100	2.6	5.4	14	27	45.8	79.5	115		
Operating temperature	°C	1, 2	3~100	-15°C~+90°C								
lubrication		1, 2	3~100	IP65								
Ingress protection		1, 2	3~100	life Lubricated								
Mounting direction		1, 2	3~100	Any								
Noise level ($n_t=3000rpm$)	dB	1, 2	3~100	≤58	≤60	≤63	≤65	≤67	≤70	≤72		

specification	series	Ratio	MKD-060	MKD-075	MKD-100	MKD-140	MKD-180	MKD-210	MKD-240	
Inertia J_1	1	3	0.16	0.61	3.25	9.21	28.98	69.61	185.05	
		4	0.14	0.48	2.74	7.54	23.67	54.37	183.43	
		5	0.13	0.47	2.71	7.42	23.29	53.27	183.43	
		6	0.13	0.45	2.65	7.25	22.75	51.72	183.43	
		7	0.13	0.45	2.62	7.14	22.48	50.97	183.43	
		8	0.13	0.44	2.58	7.07	22.59	50.84	183.43	
		9	0.13	0.44	2.57	7.04	22.53	50.63	177.26	
		10	0.13	0.44	2.57	7.03	22.51	50.56	175.39	
		2	15	0.03	0.13	0.47	2.71	7.42	23.29	53.27
			20	0.03	0.13	0.47	2.71	7.42	23.29	53.27
	25		0.03	0.13	0.47	2.71	7.42	23.29	53.27	
	30		0.03	0.13	0.47	2.71	7.42	23.29	53.27	
	35		0.03	0.13	0.47	2.71	7.42	23.29	53.27	
	40		0.03	0.13	0.47	2.71	7.42	23.29	53.27	
	45		0.03	0.13	0.47	2.71	7.42	23.29	53.27	
	50		0.03	0.13	0.44	2.57	7.03	22.51	50.56	
	60		0.03	0.13	0.44	2.57	7.03	22.51	50.56	
	70		0.03	0.13	0.44	2.57	7.03	22.51	50.56	
	80	0.03	0.13	0.44	2.57	7.03	22.51	50.56		
	90	0.03	0.13	0.44	2.57	7.03	22.51	50.56		
100	0.03	0.13	0.44	2.57	7.03	22.51	50.56			

The output speed of F_{2R} and F_{2A} is 100 rpm, acting at the center of the output shaft.

MKD Series

1-Stage :3,4,5,6,7,8,9,10

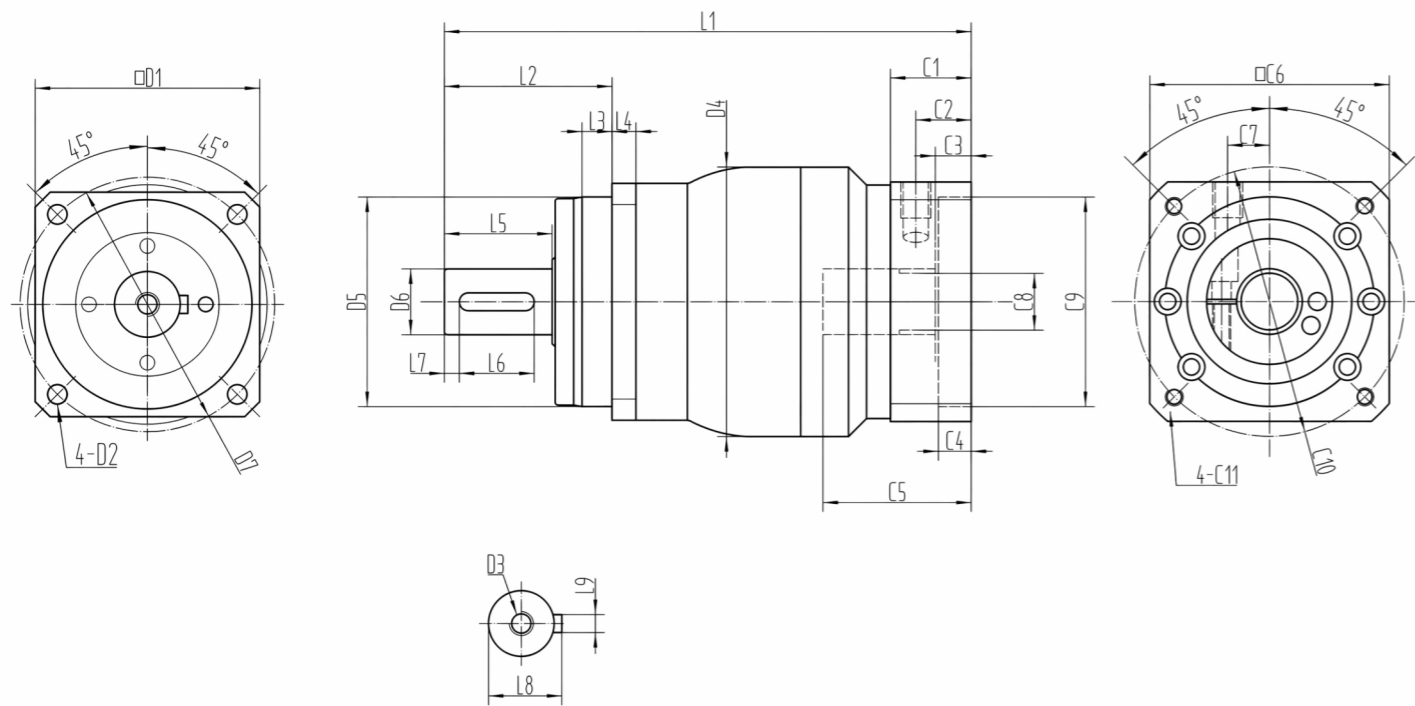

	MKD-060	MKD-075	MKD-100	MKD-140	MKD-180	MKD-210	MKD-240
L1*	137	176	240	299	367	408.5	481.5
L2	48	56	88	112	112	143	170
L3	4.5	10	8	10	27	15	37
L4	6	8	10	12	15	17	20
L5	28	36	58	82	82	105	130
L6	22	25	40	70	70	90	125
L7	2	5	10	5	6	7	3
L8	18	24.5	35	43	59	79.5	90
L9	5	6	10	12	16	20	22
D1	60	77.5	101.5	140	182	210	245
D2	5.5	6.6	9	11	13.5	17	17
D3	M5*13	M8*20	M12*28	M16*36	M20*42	M20*42	M20*42
D4	65	90	116	151	205	241	265
D5	60	70	90	130	160	180	200
D6	16	22	32	40	55	75	85
D7	68	85	120	165	215	250	290
C1*	23	27	37.5	47	76	50	65
C2*	16	18.5	26	26	55	29	44
C3*	11	12	19.5	14	45	16	29.5
C4*	10.5	11	10	8	10	10	10
C5*	37	49.5	71	85.5	114	87	124
C6*	60	80	130	176	180	200	266
C7*	10.5	14	20	27	30	30	38
C8*	14	19	24	35	42	38	55
C9*	50	70	110	114.3	114.3	180	250
C10*	70	90	145	200	200	215	300
C11*	M5*12	M6*12	M8*16	M12*25	M12*24	M12*24	M16*32

The one with * is a reference, and the size can be adjusted.

MKD Series

2-Stage :15,20,25,30,35,40,45,50,60,70,80,90,100

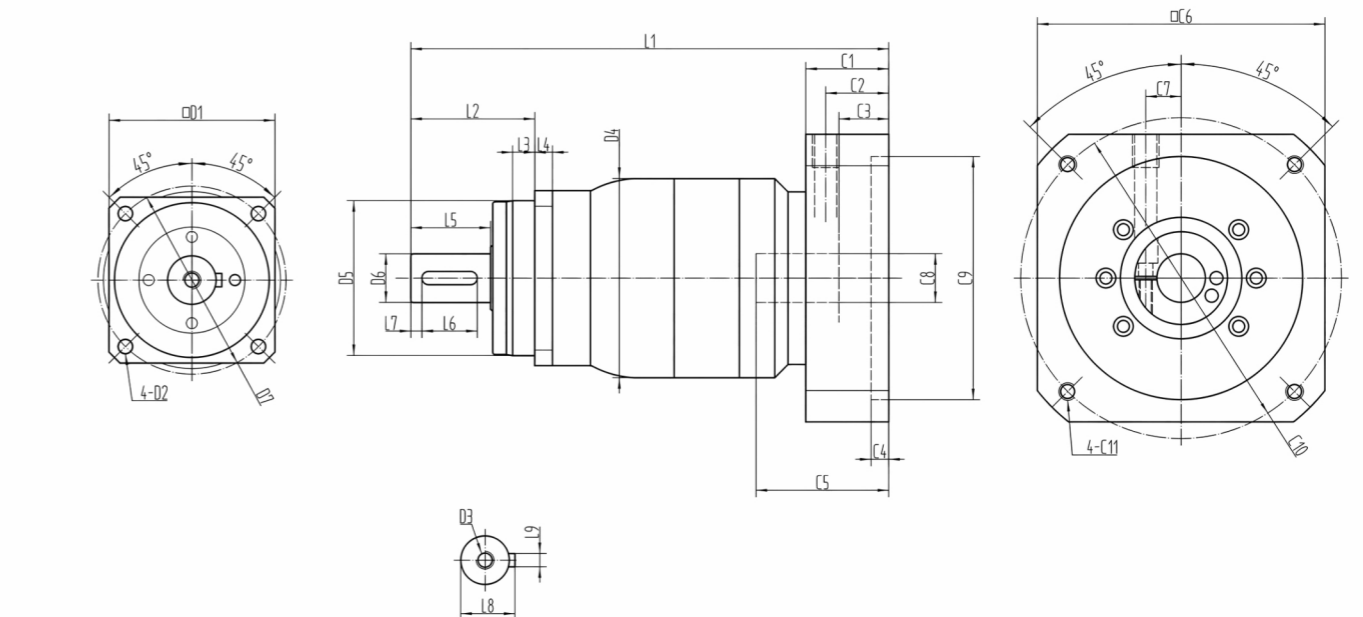

	MKD-060	MKD-075	MKD-100	MKD-140	MKD-180	MKD-210	MKD-240
L1*	157	205.5	274.5	334.5	396.5	513	579.5
L2	48	56	88	112	112	143	170
L3	5	10	8	10	27	35	37
L4	6	8	10	12	15	17	20
L5	28	36	58	82	82	105	130
L6	22	25	40	70	70	90	125
L7	2	5	10	5	6	7	3
L8	18	24.5	35	43	59	79.5	90
L9	5	6	10	12	16	20	22
D1	60	77.5	101.5	140	182	210	245
D2	5.5	6.6	9	11	13.5	17	17
D3	M5*13	M8*20	M12*28	M16*36	M20*42	M20*42	M20*42
D4	65	90	116	150	205	241	265
D5	60	70	90	130	160	180	200
D6	16	22	32	40	55	75	85
D7	68	85	120	165	215	250	290
C1*	23	27	37.5	47	50	72	96
C2*	16	18.5	26	26	29	57	63
C3*	11	12	19.5	14	19	48	48.5
C4*	10.5	11	10	8	10	10	10
C5*	36.5	49.5	71	81	88	125	149
C6*	60	80	130	176	200	220	280
C7*	10.5	14	20	27	30	35	40
C8*	14	19	24	35	38	55	55
C9*	50	70	110	114.3	180	200	250
C10*	70	90	145	200	215	235	300
C11*	M5*12	M6*15	M8*16	M12*25	M12*20	M12*24	M16*32

The one with * is a reference, and the size can be adjusted.

MKD Series

2-Stage(Smaller type) :15,20,25,30,35,40,45,50,60,70,80,90,100



MKF SERIES



High-performance series for heaviest operating duties, MKF gearboxes present high torsional stiffness, maximum power, optimum precision and compactness.

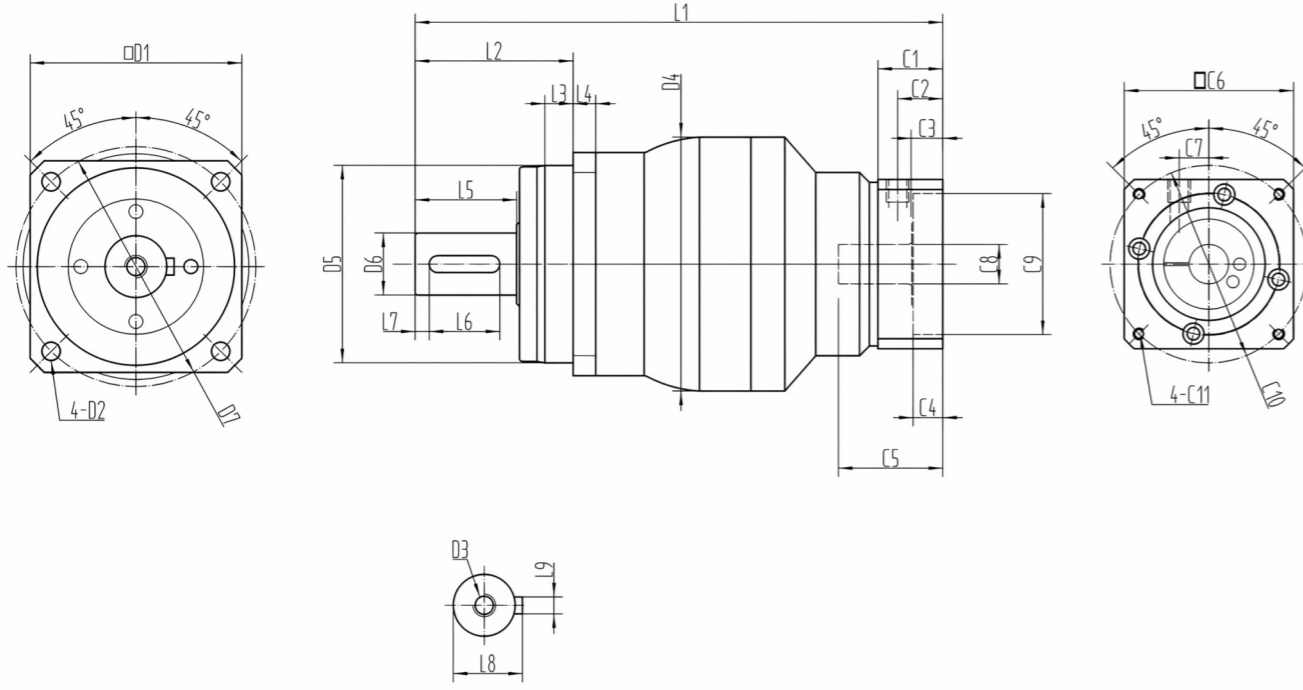

	MKD-075	MKD-100	MKD-140	MKD-180	MKD-210	MKD-240
L1*	187	243.5	317.5	377.5	491	499.5
L2	56	88	112	112	143	170
L3	10	8	10	12	15	16
L4	8	10	12	15	17	20
L5	36	58	82	82	105	130
L6	25	40	70	70	90	125
L7	5	10	5	6	7	3
L8	24.5	35	43	59	79.5	90
L9	6	10	12	16	20	22
D1	77.5	101.5	140	182	210	245
D2	6.6	9	11	13.5	17	17
D3	M8*20	M12*28	M16*36	M20*42	M20*42	M20*42
D4	90	116	150	205	241	265
D5	70	90	130	160	180	200
D6	22	32	40	55	75	85
D7	85	120	165	215	250	290
C1*	23	27	37.5	47	76	50
C2*	16	18.5	26	26	55	29
C3*	11	12	20	18	45	19
C4*	10.5	11	10	8	10	10
C5*	37	49.5	71.5	85	114	88
C6*	60	80	130	176	180	200
C7*	10.5	14	20	27	30	30
C8*	14	19	24	35	42	38
C9*	50	70	110	114.3	114.3	180
C10*	70	90	145	200	200	215
C11*	M5*10	M6*12	M8*16	M12*24	M12*24	M12*30

The one with * is a reference, and the size can be adjusted.



MKF

Selection data:

Nominal output torque (Nm)	40-3150
Reduction ratio	4-100
Backlash (arcmin)	1-7
Max.working temperature (°C)	90
Noise (dB)	56-72

specification	series	Ratio	MKF-047	MKF-064	MKF-090	MKF-110	MKF-140	MKF-200	MKD-210	MKD-240	
Rated output torque T _{2N}	1	4	19	50	140	320	550	1000	2100	3000	
		5	22	60	160	360	650	1200	2200	3150	
		6	20	55	150	350	600	1100	2200	3150	
		7	20	55	150	360	600	1100	2200	3150	
		8	20	55	140	360	550	1000	2200	3000	
		9	14	40	100	230	450	900	1600	2400	
		10	14	40	100	230	450	900	1500	2400	
		20	19	50	140	320	650	1350	2400	3000	
		25	22	60	160	330	650	1200	2550	3150	
		30	20	55	150	310	650	1100	2500	3000	
	2	35	20	60	150	360	550	1400	2500	3000	
		40	20	55	150	260	500	1000	1600	2800	
		45	14	40	100	230	450	900	1500	2700	
		50	22	60	160	360	700	1400	2550	3150	
		60	20	55	150	310	600	1100	2500	3000	
		70	19	50	140	300	550	1100	2500	2900	
		80	20	55	140	360	700	1400	2550	3150	
		90	14	40	100	230	460	980	1600	2300	
		100	14	40	100	230	460	980	1500	2300	
		Maximum output torque T _{2M}	Nm	1, 2	3~100		3 times the rated output torque				
Rated input speed n _{1N}	rpm	1, 2	3~100	5000	5000	4000	4000	3000	3000	2000	2000
Maximum input speed n _{2M}	rpm	1, 2	3~100	10000	10000	8000	8000	6000	6000	4000	4000
Backlash accuracy_H (high precision)	arcmin	1	3~10	-	-	≤1	≤1	≤1	≤1	≤1	≤1
		2	15~100	-	-	≤3	≤3	≤3	≤3	≤3	≤3
Backlash accuracy_P (precision)	arcmin	1	3~10	≤3	≤3	≤3	≤3	≤3	≤3	≤3	≤3
		2	15~100	≤5	≤5	≤5	≤5	≤5	≤5	≤5	≤5
Backlash accuracy_S (standard)	arcmin	1	3~10	≤5	≤5	≤5	≤5	≤5	≤5	≤5	≤5
		2	15~100	≤7	≤7	≤7	≤7	≤7	≤7	≤7	≤7
Torsional rigidity	Nm/arcmin	1, 2	3~100	7	13	31	82	151	450	1023	1300
Allowable radial force F _{2R}	N	1, 2	3~100	55	110	270	440	1335	3280	5500	8800
Allowable axial force F _{2A}	N	1, 2	3~100	990	1050	2850	4000	10590	16660	29430	37000
working life	hr	1, 2	3~100	20000h							
efficiency η	%	1	3~10	≥97%							
		2	15~100	≥94%							
weight	kg	1	3~100	0.7	1.45	4.1	6.2	15.8	31.6	71	105
		2	15~100	1	2.5	5	10	21.1	36.7	85	114
Operating temperature	°C	1, 2	3~100	-15°C~+90°C							
lubrication		1, 2	3~100	IP65							
Ingress protection		1, 2	3~100	life Lubricated							
Mounting direction		1, 2	3~100	Any							
Noise level (n _t =3000rpm)	dB	1, 2	3~100	≤56	≤58	≤60	≤63	≤65	≤67	≤70	≤72

specification	series	Ratio	MKF-047	MKF-064	MKF-090	MKF-110	MKF-140	MKF-200	MKD-210	MKD-240
Inertia J ₁	1	4	0.03	0.14	0.48	2.74	7.54	23.67	54.37	183.43
		5	0.03	0.13	0.47	2.71	7.42	23.29	53.27	183.43
		6	0.03	0.13	0.45	2.65	7.25	22.75	51.72	183.43
		7	0.03	0.13	0.45	2.62	7.14	22.48	50.97	183.43
		8	0.03	0.13	0.44	2.58	7.07	22.59	50.84	183.43
		9	0.03	0.13	0.44	2.57	7.04	22.53	50.63	177.26
		10	0.03	0.13	0.44	2.57	7.03	22.51	50.56	175.39
		20	0.03	0.03	0.13	0.47	2.71	7.42	23.29	53.27
		25	0.03	0.03	0.13	0.47	2.71	7.42	23.29	53.27
		30	0.03	0.03	0.13	0.47	2.71	7.42	23.29	53.27
	2	35	0.03	0.03	0.13	0.47	2.71	7.42	23.29	53.27
		40	0.03	0.03	0.13	0.47	2.71	7.42	23.29	53.27
		45	0.03	0.03	0.13	0.47	2.71	7.42	23.29	53.27
		50	0.03	0.03	0.13	0.44	2.57	7.03	22.51	50.56
		60	0.03	0.03	0.13	0.44	2.57	7.03	22.51	50.56
		70	0.03	0.03	0.13	0.44	2.57	7.03	22.51	50.56
		80	0.03	0.03	0.13	0.44	2.57	7.03	22.51	50.56
		90	0.03	0.03	0.13	0.44	2.57	7.03	22.51	50.56
		100	0.03	0.03	0.13	0.44	2.57	7.03	22.51	50.56

The output speed of F_{2R} and F_{2A} is 100 rpm, acting at the center of the output shaft.

MKF Series

1-Stage :3,4,5,6,7,8,9,10

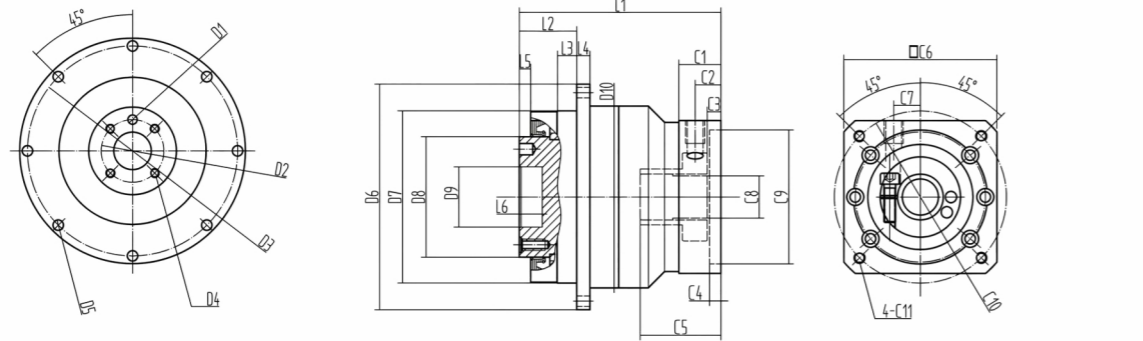

MKF-047

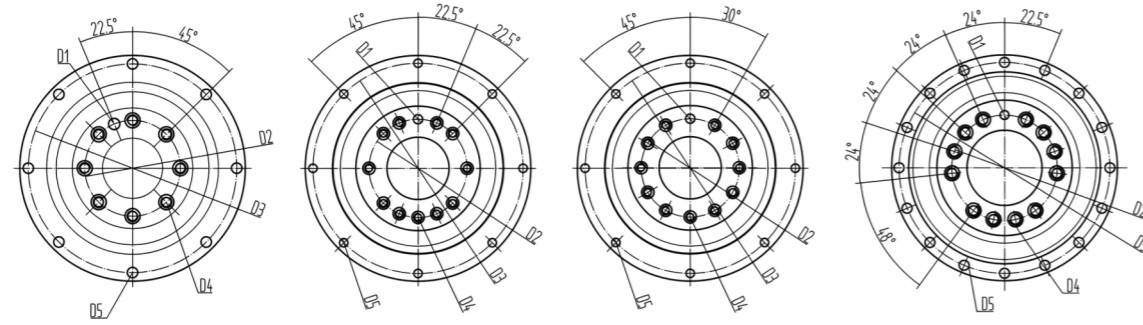

MKF-064/090

MKF-110

MKF-140/200

MKF-255/285

	MKF-047	MKF-064	MKF-090	MKF-110	MKF-140	MKF-200	MKF-255	MKF-285
L1*	68.5	85.5	105.5	151.5	173	222	225.5	271
L2	19.5	19.5	30	29	38	50	66	75
L3	7	7	10	10	14.5	15	20	20
L4	4	4	7	8	10	12	18	20
L5	3	3	6	6	6	8	12	16.5
L6	4	8	12	13	12	16	20	20
D1	φ 3*3	φ 5*8	φ 6*7	φ 6*7	φ 8*7	φ 10*10	φ 12*10	φ 20*20
D2	20	31.5	50	63	80	125	140	160
D3	67	79	109	135	168	233	280	310
D4	4-M3*6	7-M5*8	8-M6*12	11-M6*12	11-M8*17	11-M10*20	12-M16*25	12-M20*31
D5	8-φ 3.5	8-φ 4.5	8-φ 5.5	8-φ 5.5	12-φ 6.6	12-φ 9	16-φ 13.5	16-φ 13.5
D6	72	86	118	145	179	247	300	330
D7	47	64	90	110	140	200	255	285
D8	28	40	63	80	100	160	180	200
D9	12	20	31.5	40	50	80	100	120
D10	60	70	95	120	150	200	255	285
C1*	17.5	23	22	37.5	47	76	50	62
C2*	11.5	16	13.5	27	26	55	29	29
C3*	8.5	11	7	20	18	45	19	14.5
C4*	3.5	10.5	6	10	8	10	10	10
C5*	30.5	37	44.5	71.5	85	114	90.5	115
C6*	42	60	80	130	176	180	200	280
C7*	6.5	10.5	14	20	27	30	30	40
C8*	8	14	19	24	35	42	38	55
C9*	30	50	70	110	114.3	114.3	180	250
C10*	46	70	90	145	200	200	215	300
C11*	M4*8	M5*10	M6*12	M8*16	M12*25	M12*24	M12*25	M16*32

The one with * is a reference, and the size can be adjusted.

MKF Series

2-Stage :15,20,25,30,35,40,45,50,60,70,80,90,100

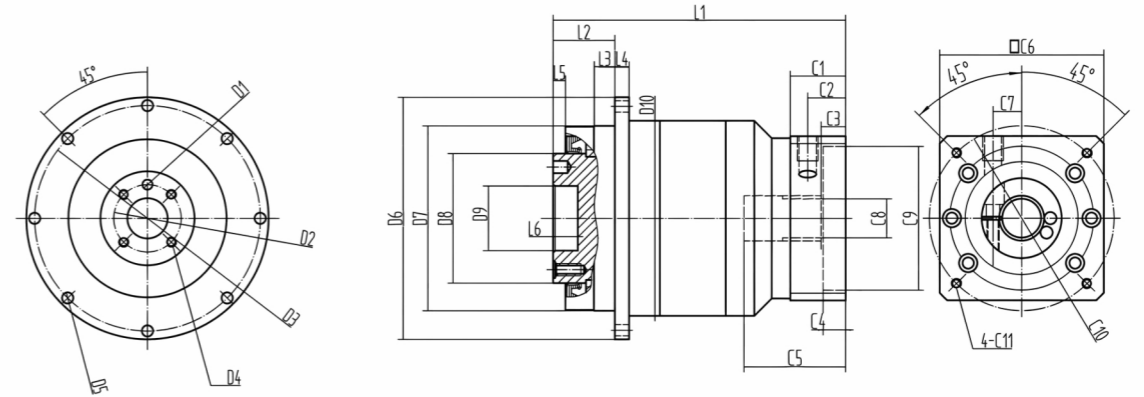

MKF-047

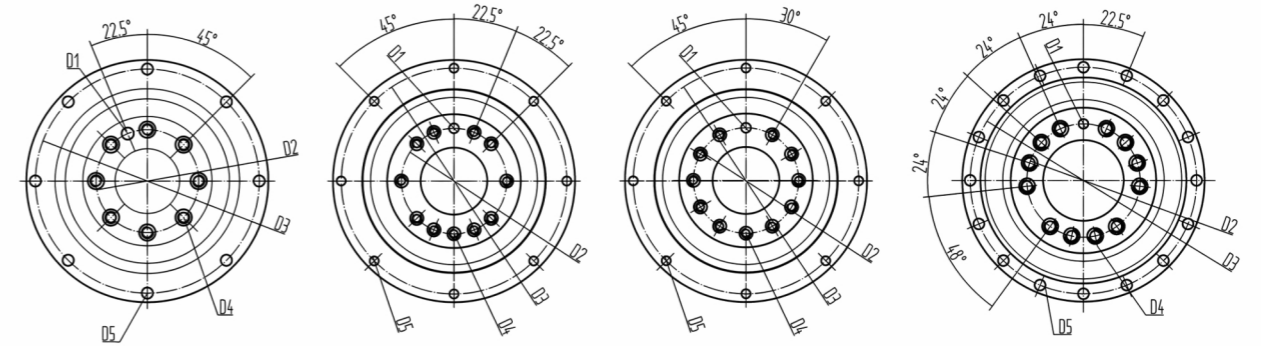

MKF-064/090

MKF-110

MKF-140/200

MKF-255/285

	MKF-047	MKF-064	MKF-090	MKF-110	MKF-140	MKF-200	MKF-255	MKF-285
L1*	86	109	142.5	185.5	218	252.5	342.5	361
L2	19.5	19.5	30	29	38	50	66	75
L3	7	7	10	10	14.5	15	20	20
L4	4	4	7	8	10	12	18	20
L5	3	3	6	6	6	8	12	16.5
L6	4	8	12	13	12	16	20	20
D1	φ 3*3	φ 5*8	φ 6*7	φ 6*7	φ 8*7	φ 10*10	φ 12*10	φ 20*20
D2	20	31.5	50	63	80	125	140	160
D3	67	79	109	135	168	233	280	310
D4	4-M3*6	7-M5*8	8-M6*12	11-M6*12	11-M8*17	11-M10*20	12-M16*25	12-M20*31
D5	8-φ 3.5	8-φ 4.5	8-φ 5.5	8-φ 5.5	12-φ 6.6	12-φ 9	16-φ 13.5	16-φ 13.5
D6	72	86	118	145	179	247	300	330
D7	47	64	90	110	140	200	255	285
D8	28	40	63	80	100	160	180	200
D9	12	20	31.5	40	50	80	100	120
D10	60	70	95	120	150	200	255	285
C1*	17.5	23	27	37.5	47	50	66.5	62
C2*	11.5	16	18.5	26	26	29	33.5	29
C3*	8.5	11	12	20	18	19	19	14.5
C4*	3.5	10.5	11	10	8	10	10	10
C5*	29.5	37	49.5	71.5	85	88	119.5	115
C6*	42	60	80	130	176	180	225	280
C7*	6.5	10.5	14	20	27	30	40	40
C8*	8	14	19	24	35	38	55	55
C9*	30	50	70	110	114.3	180	200	250
C10*	46	70	90	145	200	215	235	300
C11*	M4*8	M5*10	M6*12	M8*15	M12*24	M12*24	M12*24	M16*32

The one with * is a reference, and the size can be adjusted.

MKF Series

2-Stage(Smaller type) :15,20,25,30,35,40,45,50,60,70,80,90,100



MKBR SERIES

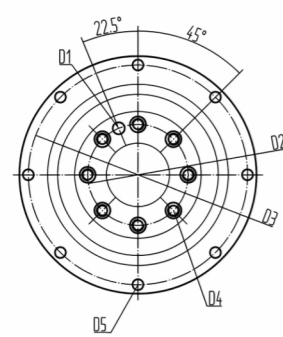
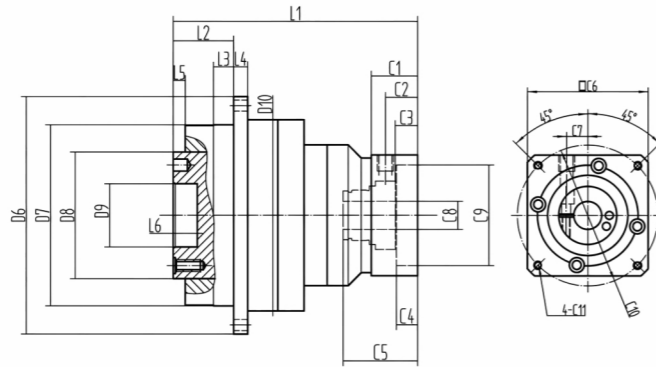

MKF-090

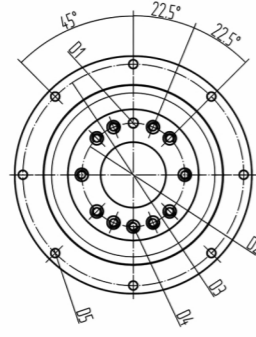

MKF-110

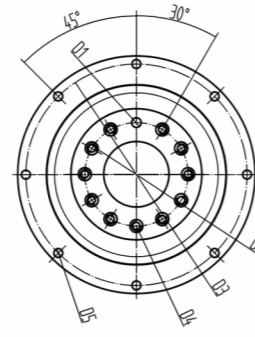

MKF-140/200

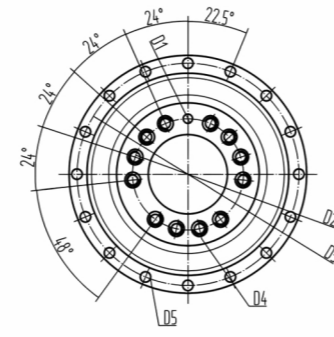

MKF-255/285



	MKF-090	MKF-110	MKF-140	MKF-200	MKF-255	MKF-285
L1*	121.5	157.5	203.5	242.5	308	331
L2	30	29	38	50	66	75
L3	10	10	14.5	15	20	20
L4	7	8	10	12	18	20
L5	6	6	6	8	12	16.5
L6	12	13	12	16	20	20
D1	φ 6*7	φ 6*7	φ 8*7	φ 10*10	φ 12*10	φ 20*20
D2	50	63	80	125	140	160
D3	109	135	168	233	280	310
D4	8-M6*12	11-M6*12	11-M8*17	11-M10*20	12-M16*25	12-M20*31
D5	8-φ 5.5	8-φ 5.5	12-φ 6.6	12-φ 9	16-φ 13.5	16-φ 13.5
D6	118	145	179	247	300	330
D7	90	110	140	200	255	285
D8	63	80	100	160	180	200
D9	31.5	40	50	80	100	120
D10	95	120	150	200	255	285
C1*	23	27	37.5	47	76	50
C2*	16	18.5	26	26	55	29
C3*	11	12	20	18	45	19
C4*	10.5	11	10	8	10	10
C5*	37	49.5	71.5	85	114	90.5
C6*	60	80	130	176	180	200
C7*	10.5	14	20	27	30	30
C8*	14	19	24	35	42	38
C9*	50	70	110	114.3	114.3	180
C10*	70	90	145	200	200	215
C11*	M5*10	M6*12	M8*16	M12*25	M12*24	M12*25

The one with * is a reference, and the size can be adjusted.

A high-performance right-angle solution for servo applications that keeps MKBR design and characteristics.

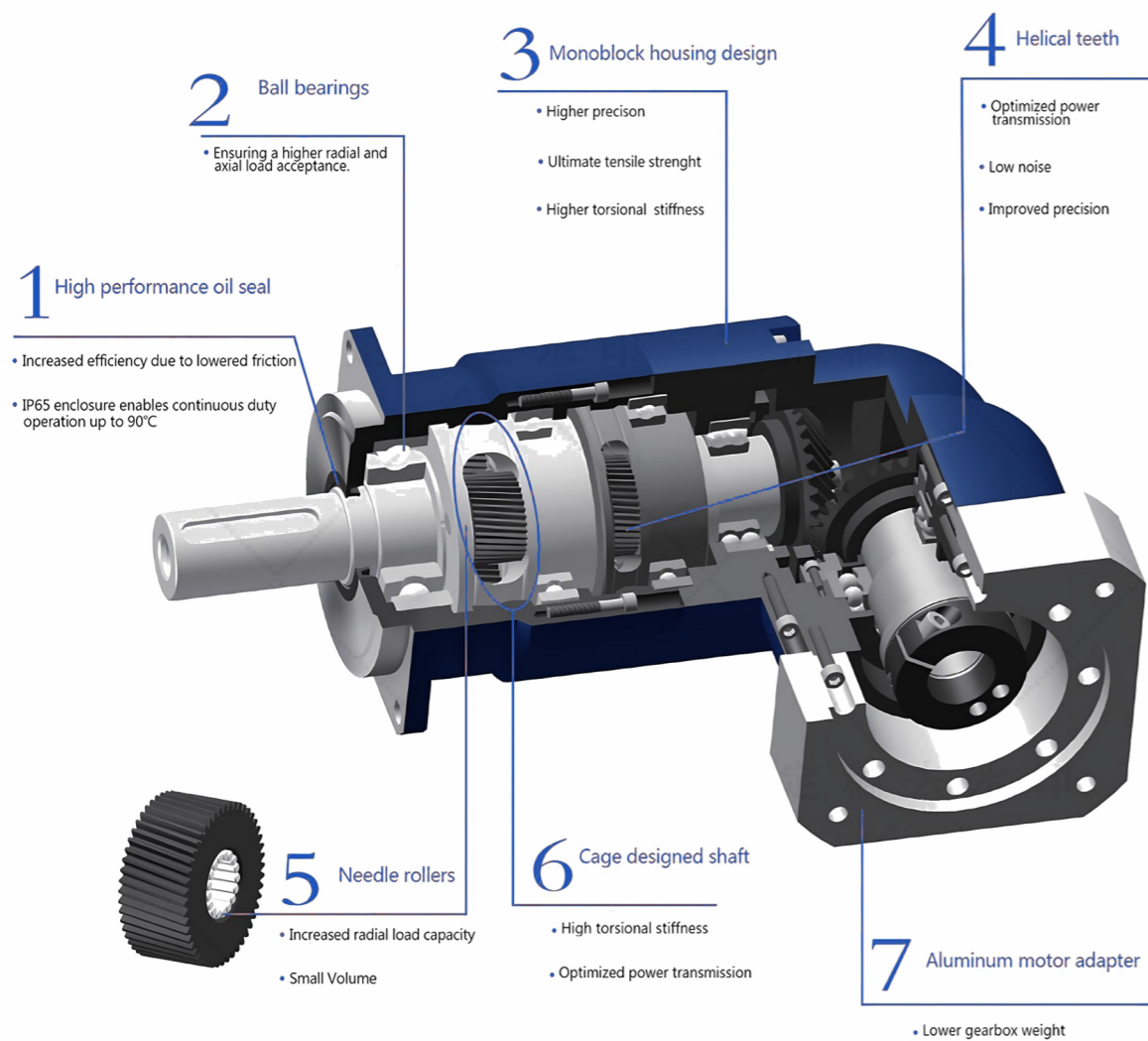

Selection data:

Nominal output torque (Nm)	9-2000
Reduction ratio	3-100
Backlash (arcmin)	4-9
Max.working temperature (°C)	90
Noise (dB)	61-74

specification	series	Ratio	MKBR-040	MKBR-060	MKBR-090	MKBR-120	MKBR-140	MKBR-180	MKBR-220	
Rated output torque T_{2M}	1	3	9	36	90	195	342	588	1140	
		4	12	48	120	200	520	1040	1680	
		5	15	60	150	260	650	1200	2000	
		6	18	55	150	325	600	1100	1900	
		7	19	50	140	310	550	1100	1800	
		8	17	45	120	300	500	1000	1600	
		9	14	40	100	260	450	900	1500	
		10	14	40	100	230	450	900	1500	
		2	15	14	30	65	200	400	880	1200
			20	14	30	85	300	600	1250	1700
	25		15	60	150	325	650	1200	2000	
	30		20	55	150	310	600	1100	1900	
	35		19	50	140	300	550	1100	1800	
	40		17	45	120	260	500	1000	1600	
	45		14	40	100	230	450	900	1500	
	50		14	60	100	230	600	1200	2000	
	60		20	55	150	310	550	1100	1900	
	70		19	50	140	300	500	1100	1800	
	80	17	45	120	260	600	1000	1600		
	90	14	40	100	230	450	900	1500		
100	14	40	100	230	450	900	1500			
Maximum output torque T_{2M}	Nm	1, 2	3 times the rated output torque							
Rated input speed n_{1N}	rpm	1, 2	3~100	5000	5000	4000	4000	3000	3000	2000
Maximum input speed n_{2M}	rpm	1, 2	3~100	10000	10000	8000	8000	6000	6000	4000
Backlash accuracy_H (high precision)	arcmin	1	3~10	-	-	-	-	-	-	-
		2	15~100	-	-	-	-	-	-	-
Backlash accuracy_P (precision)	arcmin	1	3~10	≤4	≤4	≤4	≤4	≤4	≤4	≤4
		2	15~100	≤7	≤7	≤7	≤7	≤7	≤7	≤7
Backlash accuracy_S (standard)	arcmin	1	3~10	≤6	≤6	≤6	≤6	≤6	≤6	≤6
		2	15~100	≤9	≤9	≤9	≤9	≤9	≤9	≤9
Torsional rigidity	Nm/arcmin	1, 2	3~100	3	8	20	41	50	145	225
Allowable radial force F_{2R}	N	1, 2	3~100	780	1500	3200	6700	9400	14500	50000
Allowable axial force F_{2A}	N	1, 2	3~100	610	1050	2300	4100	8300	13500	25000
working life	hr	1, 2	3~100	20000h						
efficiency η	%	1	3~10	≥95%						
		2	15~100	≥92%						
weight	kg	1	3~100	1	2.8	6.1	13	26.3	51	83
		2	15~100	1.5	3.2	7.7	14.2	28.5	54	95
Operating temperature	°C	1, 2	3~100	-15°C~+90°C						
lubrication		1, 2	3~100	IP65						
Ingress protection		1, 2	3~100	Life Lubricated						
Mounting direction		1, 2	3~100	Any						
Noise level (n_t=3000rpm)	dB	1, 2	3~100	≤61	≤63	≤65	≤68	≤70	≤72	≤74

specification	series	Ratio	MKBR-040	MKBR-060	MKBR-090	MKBR-120	MKBR-140	MKBR-180	MKBR-220
Inertia J₁	1	3~10	0.09	0.35	2.25	6.84	21.8	95.6	135.4
	2	12~100	0.09	0.09	0.35	2.25	6.84	21.8	95.6

The output speed of F_{2R} and F_{2A} is 100 rpm, acting at the center of the output shaft.

MKBR Series

1-Stage :3,4,5,6,7,8,9,10

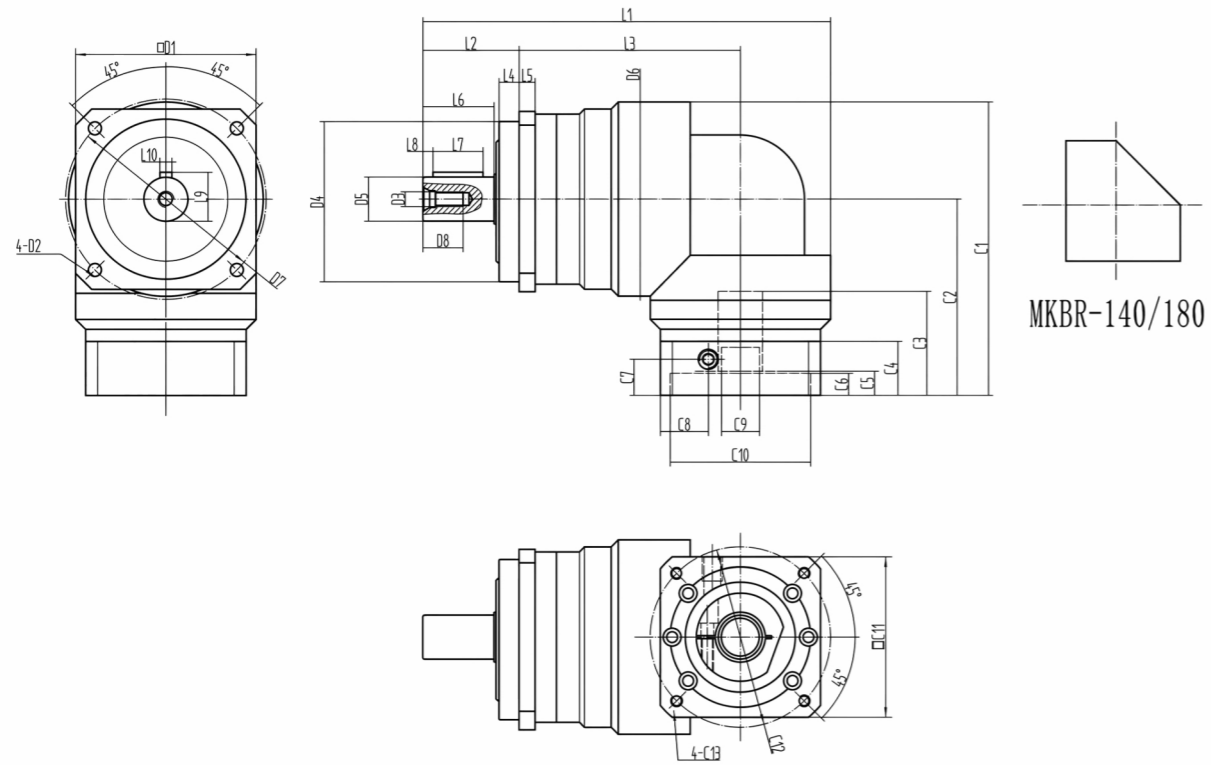

MKBR Series

2-Stage :15,20,25,30,35,40,45,50,60,70,80,90,100

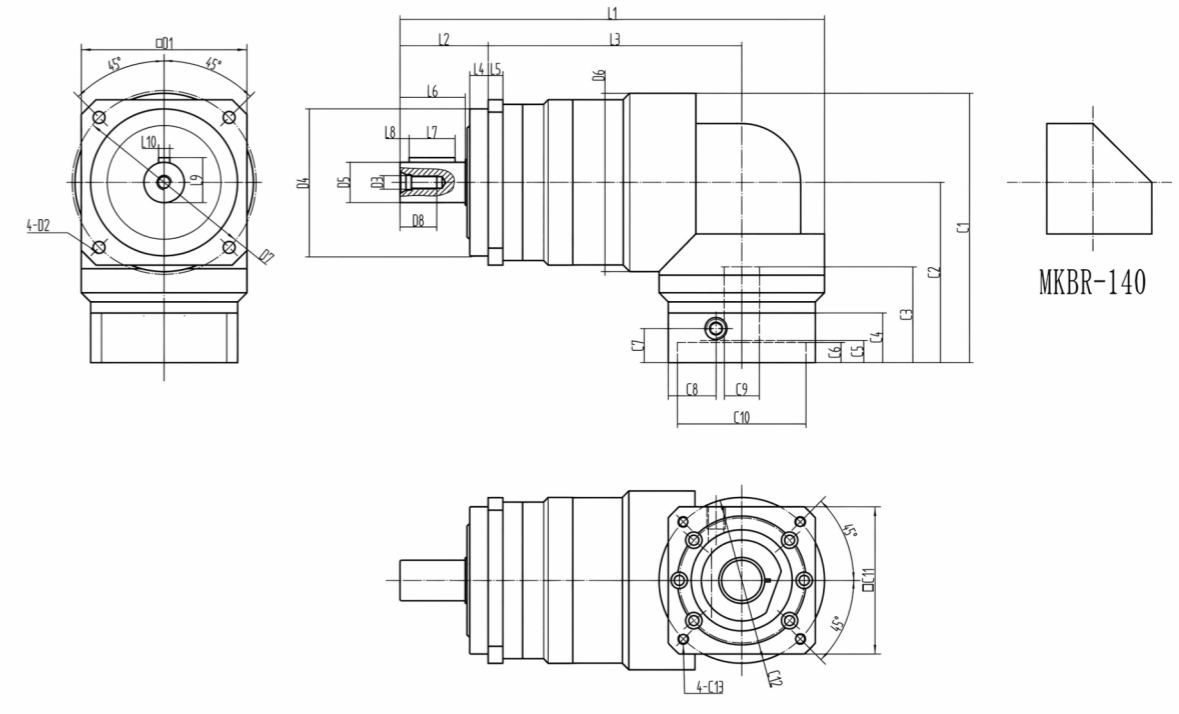

	MKBR-040	MKBR-060	MKBR-090	MKBR-120	MKBR-140	MKBR-180
L1*	109	159	203.5	261	346	406.5
L2	24.5	37	48	65	97	105
L3	63.5	89.5	110.5	135	174	211.5
L4	4	7	10	12	12	20
L5	4	8	8	12	12	15
L6	19.5	28.5	35.5	49.5	82	82
L7	15	25	32	40	65	70
L8	2	2	2	5	5	6
L9	15	18	24.5	35	43	59
L10	5	5	6	10	12	16
D1	42	60	90	115	140	180
D2	3.4	5.5	6.6	9	11	13.5
D3	M4	M5	M8	M12	M16	M20
D4	35	50	80	110	130	160
D5	13	16	22	32	40	55
D6	46	70	97	122	150	200
D7	50	70	100	130	165	215
D8	10	12	20	28	36	42
C1*	70	115.5	146.5	187.5	236.5	339.5
C2*	47	80.5	98	126.5	161.5	239.5
C3*	27	35	52	71	83	116
C4*	17.5	23	27	37.5	47	97
C5*	7	11	11	17	16	65
C6*	3.5	10.5	11	10	8	10
C7*	11.5	16	18	26	26	76
C8*	11.75	19.5	24	45	61	60
C9*	8	14	19	24	35	42
C10*	30	50	70	110	114.3	114.3
C11*	42	60	80	130	176	176
C12*	46	70	90	145	200	200
C13*	M4*8	M5*10	M5*10	M8*16	M12*24	M12*28

The one with * is a reference, and the size can be adjusted.

	MKBR-040	MKBR-060	MKBR-090	MKBR-120	MKBR-140
L1*	124	179	231	294.5	390
L2	24.5	37	48	65	97
L3	78.5	109.5	138	168.5	218
L4	4	7	10	12	12
L5	4	8	8	12	12
L6	19.5	28.5	35.5	49.5	82
L7	15	25	30	40	65
L8	2	2	2	5	5
L9	15	18	24.5	35	43
L10	5	5	6	10	12
D1	42	60	90	115	140
D2	3.4	5.5	6.6	9	11
D3	M4	M5	M8	M12	M16
D4	35	50	80	110	130
D5	13	16	22	32	40
D6	46	70	97	122	150
D7	50	70	100	130	165
D8	10	12	20	28	36
C1*	70	115.5	146.5	187.5	236.5
C2*	47	80.5	98	126.5	161.5
C3*	27	35	52	71	83
C4*	17.5	23	27	37.5	47
C5*	7	11	12	17	16
C6*	3.5	10.5	11	10	8
C7*	11.5	16	18.5	26	26
C8*	14.5	19.5	24	40	61
C9*	8	14	19	22	35
C10*	30	50	70	110	114.3
C11*	42	60	80	130	176
C12*	46	70	90	145	200
C13*	M4*8	M5*10	M6*12	M8*16	M12*24

The one with * is a reference, and the size can be adjusted.

MKBR Series

2-Stage(Smaller type) :15,20,25,30,35,40,45,50,60,70,80,90,100



MKER SERIES

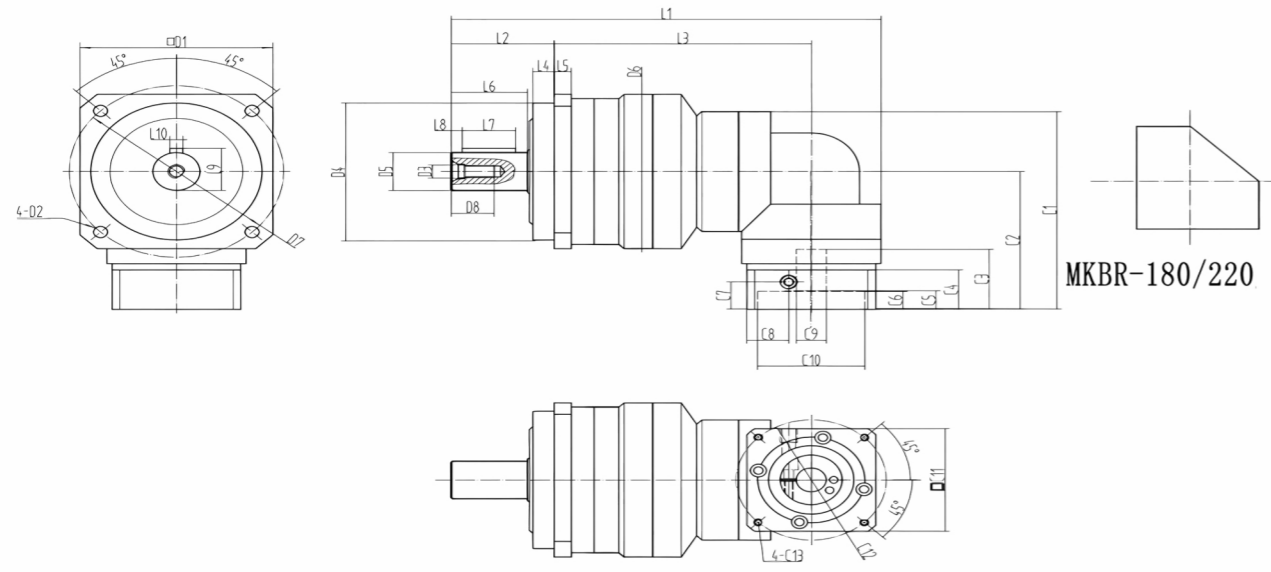

	MKBR-090	MKBR-120	MKBR-140	MKBR-180	MKBR-220
L1*	200.5	256	343.5	407	488
L2	48	65	97	105	138
L3	120	146	185.5	227	260
L4	10	12	12	20	30
L5	8	12	12	15	20
L6	35.5	49.5	82	82	105
L7	30	40	65	70	90
L8	2	5	5	6	7
L9	24.5	35	43	59	79.5
L10	6	10	12	16	20
D1	90	115	140	180	220
D2	6.6	9	11	13.5	17
D3	M8	M12	M16	M20	M20
D4	80	110	130	160	180
D5	22	32	40	55	75
D6	90	122	150	200	225
D7	100	130	165	215	250
D8	20	28	36	42	42
C1*	125.5	159	201.5	261.5	352
C2*	80.5	98	126.5	161.5	239.5
C3*	35	53	71	83	118
C4*	23	27	37.5	47	97
C5*	11	12	17	16	67
C6*	10.5	11	10	8	10
C7*	16	18	25	26	76
C8*	19.5	24	45	64	60
C9*	14	19	24	35	42
C10*	50	70	110	114.3	114.3
C11*	60	80	130	176	176
C12*	70	90	145	200	200
C13*	M5*10	M6*12	M8*16	M12*24	M12*24

The one with * is a reference, and the size can be adjusted.



A high-performance right-angle solution for servo applications that keeps MKER design and characteristics.

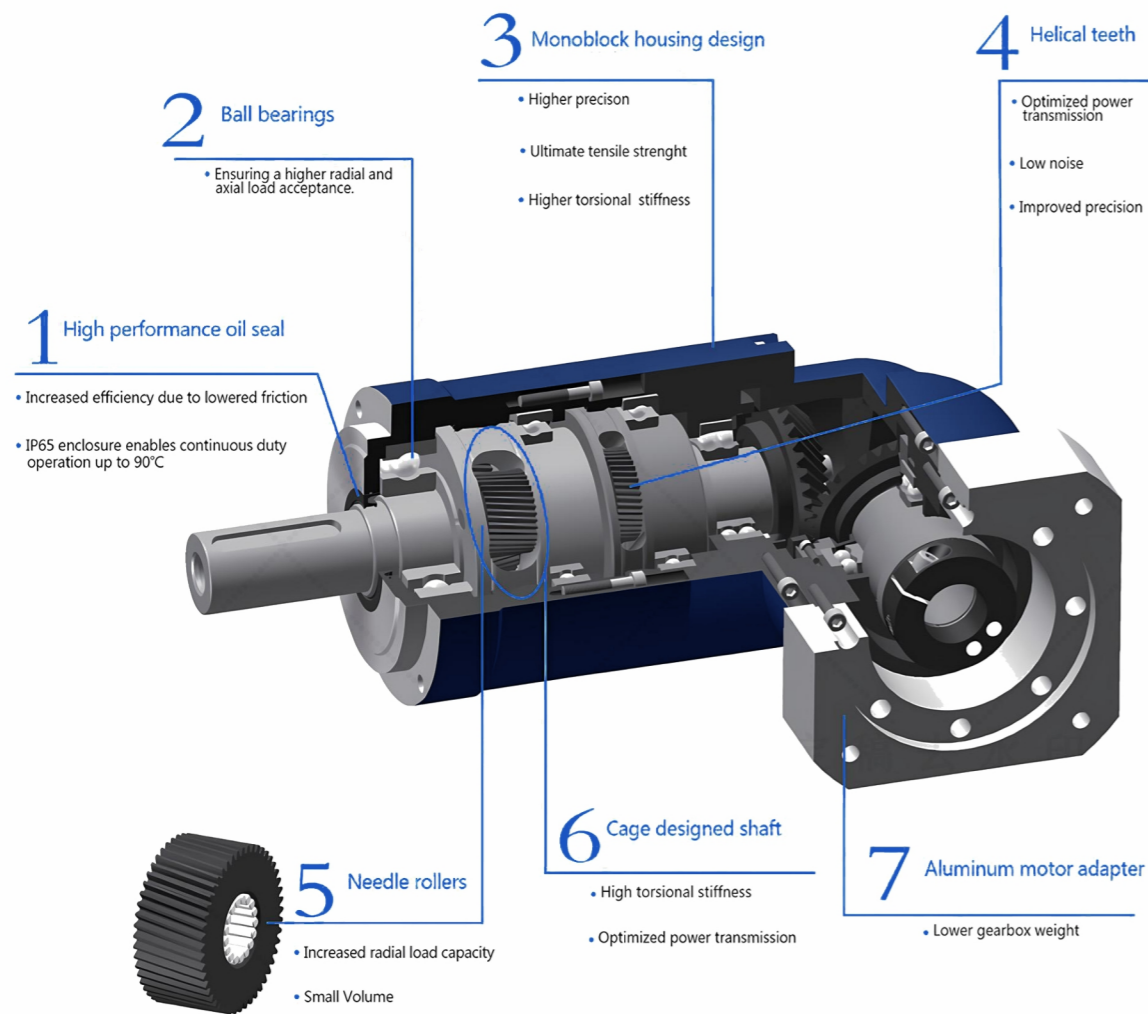

Selection data:

Nominal output torque (Nm)	9-2000
Reduction ratio	3-100
Backlash (arcmin)	4-9
Max.working temperature (°C)	90
Noise (dB)	61-74



specification	series	Ratio	MKER-040	MKER-060	MKER-090	MKER-120	MKER-155	MKER-205	MKER-235	
Rated output torque T_{2M}	1	3	9	36	90	195	342	588	1140	
		4	12	48	120	200	520	1040	1680	
		5	15	60	150	260	650	1200	2000	
		6	18	55	150	325	600	1100	1900	
		7	19	50	140	310	550	1100	1800	
		8	17	45	120	300	500	1000	1600	
		9	14	40	100	260	450	900	1500	
		10	14	40	100	230	450	900	1500	
		2	15	14	30	65	200	400	880	1200
			20	14	30	85	300	600	1250	1700
	25		15	60	150	325	650	1200	2000	
	30		20	55	150	310	600	1100	1900	
	35		19	50	140	300	550	1100	1800	
	40		17	45	120	260	500	1000	1600	
	45		14	40	100	230	450	900	1500	
	50		14	60	100	230	600	1200	2000	
	60		20	55	150	310	550	1100	1900	
	70	19	50	140	300	500	1100	1800		
	80	17	45	120	260	600	1000	1600		
90	14	40	100	230	450	900	1500			
100	14	40	100	230	450	900	1500			
Maximum output torque T_{2M}	Nm	1, 2	3~100	3 times the rated output torque						
Rated input speed n_{1N}	rpm	1, 2	3~100	5000	5000	4000	4000	3000	3000	2000
Maximum input speed n_{2M}	rpm	1, 2	3~100	10000	10000	8000	8000	6000	6000	4000
Backlash accuracy_H (high precision)	arcmin	1	3~10	-	-	-	-	-	-	-
		2	15~100	-	-	-	-	-	-	-
Backlash accuracy_P (precision)	arcmin	1	3~10	≤4	≤4	≤4	≤4	≤4	≤4	≤4
		2	15~100	≤7	≤7	≤7	≤7	≤7	≤7	≤7
Backlash accuracy_S (standard)	arcmin	1	3~10	≤6	≤6	≤6	≤6	≤6	≤6	≤6
		2	15~100	≤9	≤9	≤9	≤9	≤9	≤9	≤9
Torsional rigidity	Nm/arcmin	1, 2	3~100	3	8	20	41	50	145	225
Allowable radial force F_{2R}	N	1, 2	3~100	780	1500	3200	6700	9400	14500	50000
Allowable axial force F_{2A}	N	1, 2	3~100	610	1050	2300	4100	8300	13500	25000
working life	hr	1, 2	3~100	20000h						
efficiency η	%	1	3~10	≥95%						
		2	15~100	≥92%						
weight	kg	1	3~100	1	2.8	6.1	13	26.3	51	83
		2	15~100	1.5	3.2	7.7	14.2	28.5	54	95
Operating temperature	°C	1, 2	3~100	-15°C~+90°C						
lubrication		1, 2	3~100	IP65						
Ingress protection		1, 2	3~100	Life Lubricated						
Mounting direction		1, 2	3~100	Any						
Noise level (n_t=3000rpm)	dB	1, 2	3~100	≤61	≤63	≤65	≤68	≤70	≤72	≤74
specification	series	Ratio	MKER-040	MKER-060	MKER-090	MKER-120	MKER-155	MKER-205	MKER-235	
Inertia J₁	kg.cm ²	1	3~10	0.09	0.35	2.25	6.84	21.8	95.6	135.4
		2	12~100	0.09	0.09	0.35	2.25	6.84	21.8	95.6

The output speed of F_{2R} and F_{2A} is 100 rpm, acting at the center of the output shaft.

MKER Series

1-Stage :3,4,5,6,7,8,9,10

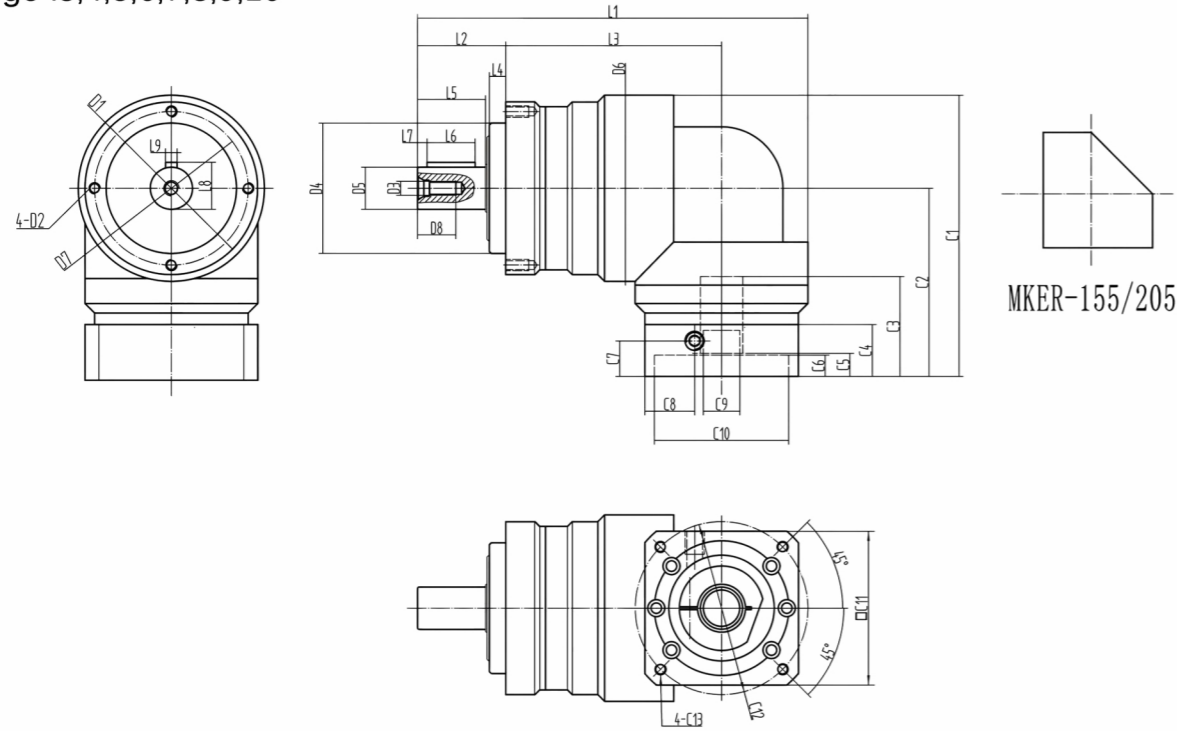

MKER-155/205

	MKER-040	MKER-060	MKER-090	MKER-120	MKER-155	MKER-205
L1*	109	159	203.5	261	346	406.5
L2	24.5	36.5	46	68.5	97	100
L3	63.5	90	112.5	131.5	174	216.5
L4	4	6.5	8.5	17.5	12	15
L5	19.5	28.5	35.5	49.5	82	82
L6	15	25	32	40	65	70
L7	2	2	2	5	5	6
L8	13.5	18	24.5	35	43	59
L9	4	5	6	10	12	16
D1	50	70	90	120	155	205
D2	M4*8	M5*10	M6*12	M8*16	M10*20	M12*25
D3	M4	M5	M8	M12	M16	M20
D4	35	52	68	90	120	160
D5	12	16	22	32	40	55
D6	46	70	97	122	150	200
D7	44	62	80	108	140	184
D8	10	12	20	28	36	42
C1*	70	115.5	146.5	187.5	236.5	287.5
C2*	47	80.5	98	126.5	161.5	187.5
C3*	27	35	52	71	83	90
C4*	17.5	23	27	37.5	47	45
C5*	7	11	11	17	16	13
C6*	3.5	10.5	11	10	8	10
C7*	11.5	16	18.5	26	26	24
C8*	14.5	19.5	26	45	61	60
C9*	8	14	19	24	35	42
C10*	30	50	70	110	114.3	114.3
C11*	42	60	80	130	176	180
C12*	46	70	90	145	200	200
C13*	M4*8	M5*10	M6*12	M8*16	M12*24	M12*24

The one with * is a reference, and the size can be adjusted.

MKER Series

2-Stage :15,20,25,30,35,40,45,50,60,70,80,90,100

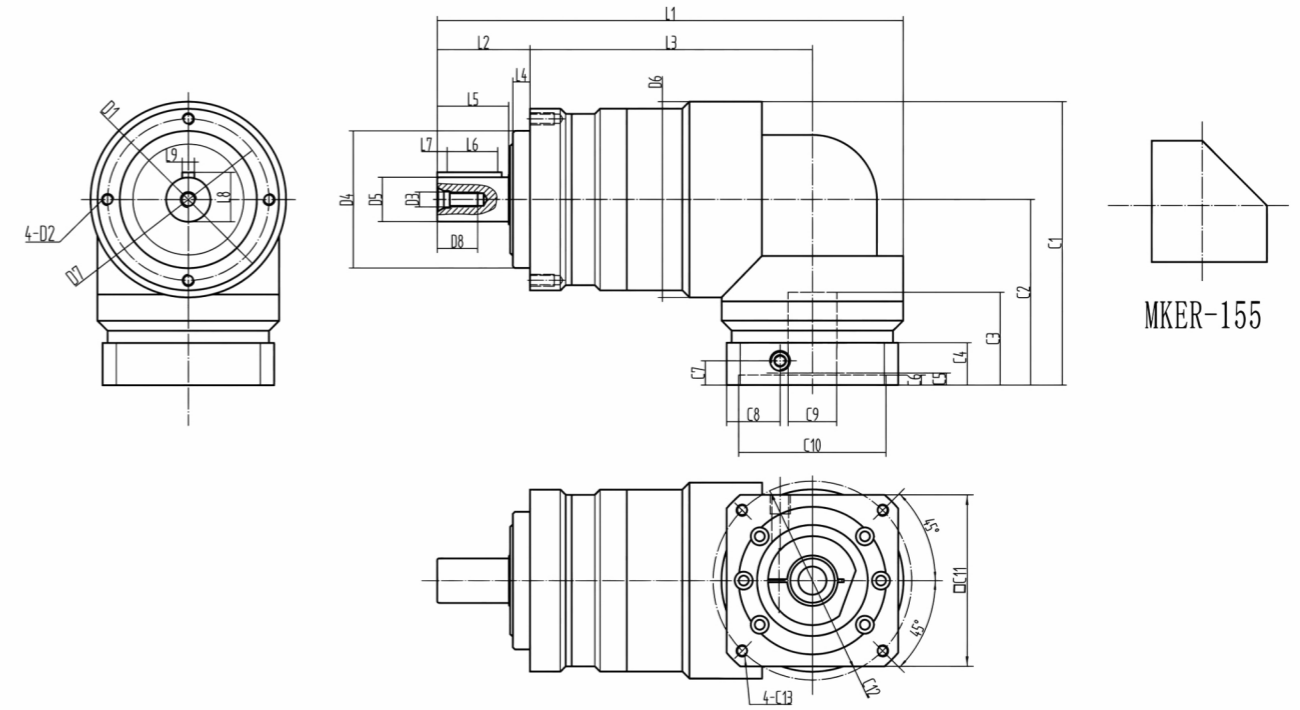

MKER-155

	MKER-040	MKER-060	MKER-090	MKER-120	MKER-155
L1*	126	179	231	294.5	390
L2	24.5	36.5	46	68.5	97
L3	80.5	110	140	165	218
L4	4	6.5	8.5	17.5	12
L5	19.5	28.5	35.5	49.5	82
L6	15	25	32	40	65
L7	2	2	2	5	5
L8	13.5	18	24.5	35	43
L9	4	5	6	10	12
D1	50	70	90	120	155
D2	M4*8	M5*10	M6*12	M8*16	M10*20
D3	M4	M5	M8	M12	M16
D4	35	52	68	110	120
D5	12	16	22	32	40
D6	46	70	97	122	150
D7	44	62	80	108	140
D8	10	12	20	28	36
C1*	70	115.5	146.5	187.5	236.5
C2*	47	80.5	98	126.5	161.5
C3*	27	35	52	71	83
C4*	17.5	23	27	37.5	47
C5*	7	10.5	12	17	16
C6*	3.5	10.5	11	10	8
C7*	11.5	16	18	26	26
C8*	14.5	19.5	26	45	61
C9*	8	14	19	24	35
C10*	30	50	70	110	114.3
C11*	42	60	80	130	176
C12*	46	70	90	145	200
C13*	M4*8	M5*10	M6*12	M8*16	M12*24

The one with * is a reference, and the size can be adjusted.

MKER Series

2-Stage(Smaller type) :15,20,25,30,35,40,45,50,60,70,80,90,100

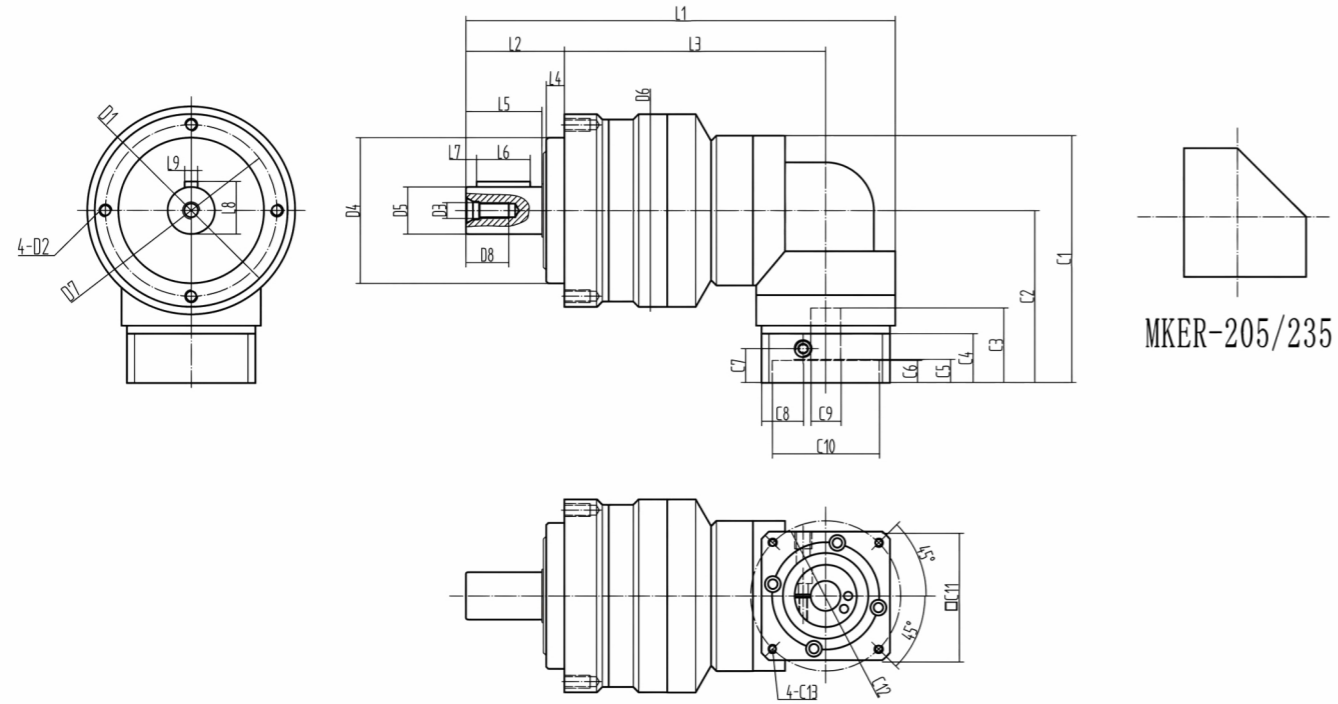

MKDR SERIES



	MKER-090	MKER-120	MKER-155	MKER-205	MKER-235
L1*	200.5	256	343.5	407	488
L2	46	68.5	97	100	126
L3	122	142.5	185.5	232	272
L4	8.5	17.5	12	15	18
L5	35.5	49.5	82	82	105
L6	30	40	65	70	90
L7	2	5	5	6	7
L8	24.5	35	43	59	79.5
L9	6	10	12	16	20
D1	90	120	155	205	235
D2	M6*12	M8*16	M10*20	M12*24	M16*28
D3	M8	M12	M16	M20	M20
D4	68	90	120	160	180
D5	22	32	40	55	75
D6	90	122	150	200	225
D7	80	108	140	184	210
D8	20	28	36	42	42
C1*	125.5	159	201.5	261.5	352
C2*	80.5	98	126.5	161.5	239.5
C3*	35	52	71	83	118
C4*	23	27	37.5	47	97
C5*	11	12	17	16	67
C6*	10.5	11	10	8	10
C7*	16	18.5	27	26	76
C8*	19.5	26	45	64	60
C9*	14	19	24	35	42
C10*	50	70	110	114.3	114.3
C11*	60	80	130	176	176
C12*	70	90	145	200	200
C13*	M5*10	M6*12	M8*16	M12*25	M12*24

The one with * is a reference, and the size can be adjusted.

A high-performance right-angle solution for servo applications that keeps MKDR design and characteristics.

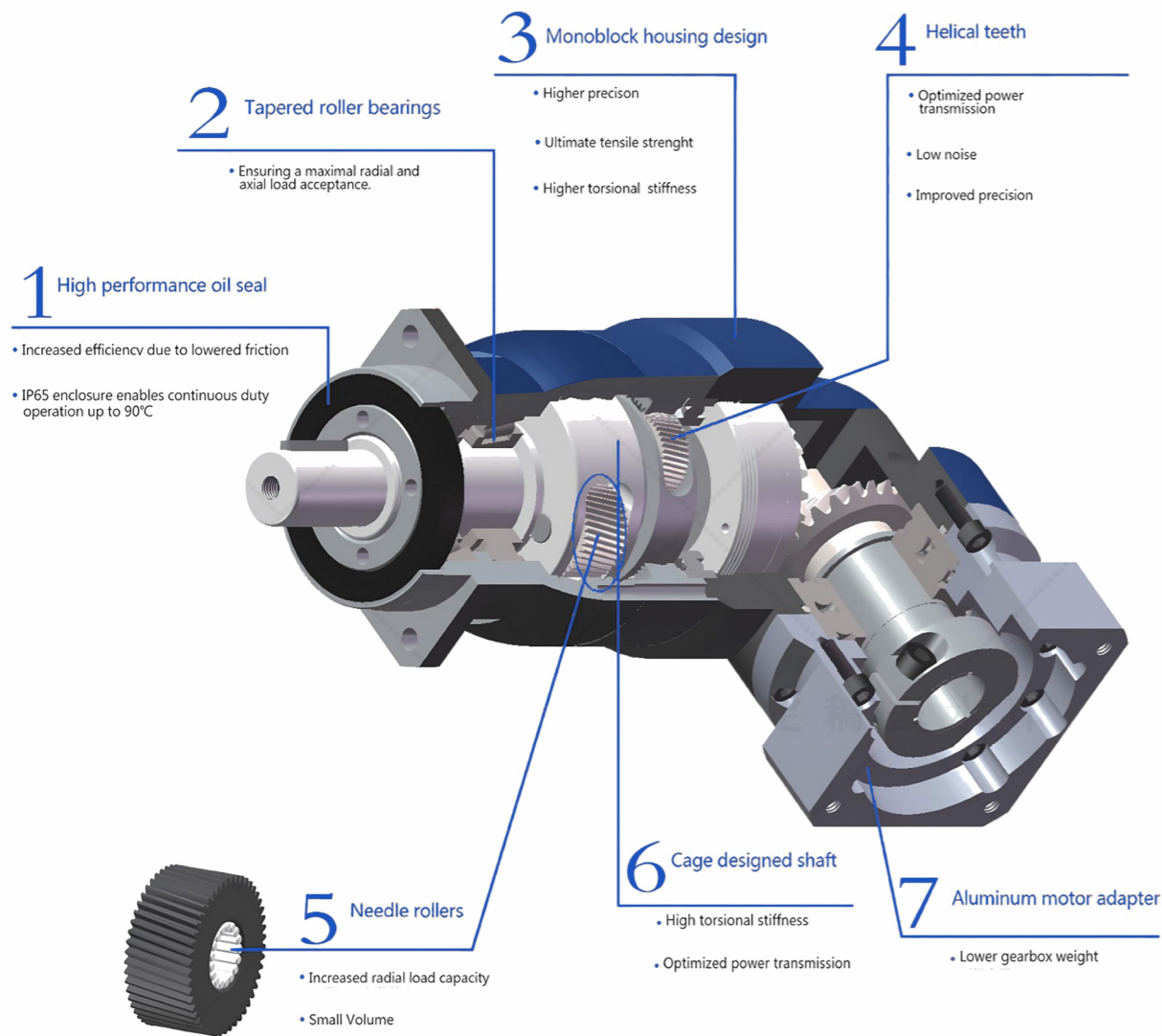

Selection data:

Nominal output torque (Nm)	40-2550
Reduction ratio	3-100
Backlash (arcmin)	4-9
Max.working temperature (°C)	90
Noise (dB)	63-74

MKDR

specification	series	Ratio	MKDR-060	MKDR-075	MKDR-100	MKDR-140	MKDR-180	MKDR-210	
Rated output torque T_{2N}	1	3	55	130	240	350	1100	2000	
		4	50	140	320	550	1700	2100	
		5	60	160	360	650	2000	2200	
		6	55	150	350	600	1900	2200	
		7	55	150	360	600	1800	2200	
		8	55	140	360	550	1800	2200	
		9	40	100	230	450	1500	2000	
		10	40	100	230	450	1500	2000	
		2	15	55	130	240	460	1300	2400
			20	50	140	320	650	1800	2400
	25		60	160	330	650	2000	2550	
	30		55	150	310	650	1900	2500	
	35		60	150	360	550	1900	2500	
	40		55	150	260	500	1600	2000	
	45		40	100	230	450	1500	2000	
	50		60	160	360	700	2000	2550	
	60		55	150	310	600	1900	2500	
	70		50	140	300	550	1800	2500	
	80	55	140	360	700	1900	2550		
	90	40	100	230	460	1500	2000		
100	40	100	230	460	1500	2000			
Maximum output torque T_{2M}	Nm	1, 2	3~100	3 times the rated output torque					
Rated input speed n_{1N}	rpm	1, 2	3~100	5000	4000	4000	3000	3000	2000
Maximum input speed n_{2M}	rpm	1, 2	3~100	10000	8000	8000	6000	6000	4000
Backlash accuracy_H (high precision)	arcmin	1	3~10	-	-	-	-	-	-
		2	15~100	-	-	-	-	-	-
Backlash accuracy_P (precision)	arcmin	1	3~10	≤4	≤4	≤4	≤4	≤4	≤4
		2	15~100	≤7	≤7	≤7	≤7	≤7	≤7
Backlash accuracy_S (standard)	arcmin	1	3~10	≤6	≤6	≤6	≤6	≤6	≤6
		2	15~100	≤9	≤9	≤9	≤9	≤9	≤9
Torsional rigidity	Nm/arcmin	1, 2	3~100	7	14	31	53	175	400
Allowable radial force F_{2R}	N	1, 2	3~100	3000	4200	9200	14000	18500	33000
Allowable axial force F_{2A}	N	1, 2	3~100	2700	3900	6200	11400	19500	21000
working life	hr	1, 2	3~100	20000h					
efficiency η	%	1	3~10	≥95%					
		2	15~100	≥92%					
weight	kg	1	3~100	3.1	6	8.1	35.5	60	83
		2	15~100	3.6	7.4	9.1	21.4	66	90
Operating temperature	°C	1, 2	3~100	-15°C~+90°C					
lubrication		1, 2	3~100	IP65					
Ingress protection		1, 2	3~100	Life Lubricated					
Mounting direction		1, 2	3~100	Any					
Noise level (n_t=3000rpm)	dB	1, 2	3~100	≤63	≤65	≤68	≤70	≤72	≤74

specification	series	Ratio	MKDR-060	MKDR-075	MKDR-100	MKDR-140	MKDR-180	MKDR-210	
Inertia J₁	kg.cm ²	1	3~10	0.35	2.25	6.84	21.8	95.6	135.4
		2	12~100	0.09	0.35	2.25	6.84	21.8	95.6

The output speed of F_{2R} and F_{2A} is 100 rpm, acting at the center of the output shaft.

MKDR Series

1-Stage :3,4,5,6,7,8,9,10

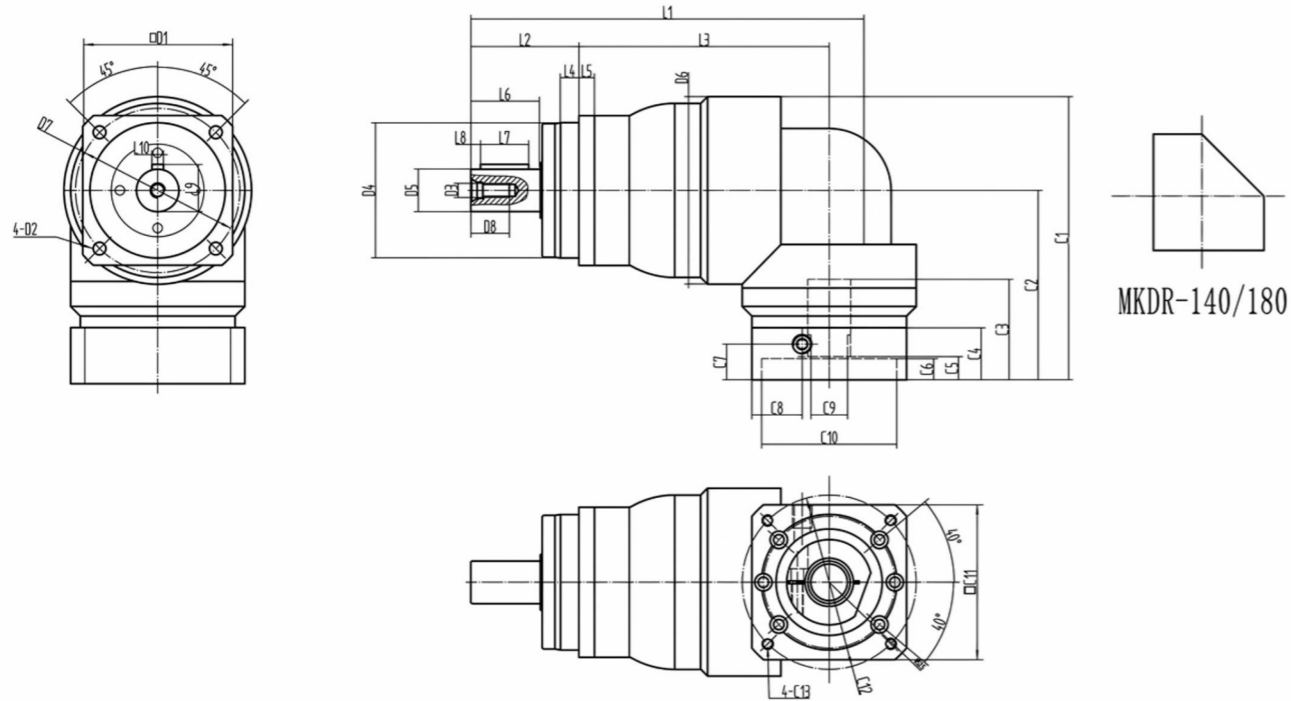

	MKDR-060	MKDR-075	MKDR-100	MKDR-140	MKDR-180
L1*	178.5	230.5	301	383.5	475
L2	48	56	88	112	112
L3	98	129.5	152	196.5	273
L4	5	10	8	10	12
L5	6	8	10	12	15
L6	28	36	58	82	82
L7	22	25	40	70	70
L8	2	5	10	5	6
L9	18	24.5	35	43	59
L10	5	6	10	12	16
D1	60	77.5	101.5	140	182
D2	5.5	6.6	9	11	13.5
D3	M5	M8	M12	M16	M20
D4	60	70	90	130	160
D5	16	22	32	40	55
D6	70	97	122	150	205
D7	68	85	120	165	215
D8	12	20	28	36	42
C1*	115.5	146.5	187.5	236.5	340
C2*	80.5	98	126.5	161.5	237.5
C3*	35	52	71	83	140
C4*	23	27	37.5	47	97
C5*	11	12	17	16	65
C6*	10.5	11	10	8	10
C7*	16	18.5	25	26	76
C8*	19.5	26	45	61	63
C9*	14	19	24	35	42
C10*	50	70	110	114.3	114.3
C11*	60	80	130	176	180
C12*	70	90	145	200	200
C13*	M5*10	M6*12	M8*16	M12*24	M12*24

The one with * is a reference, and the size can be adjusted.

MKDR Series

2-Stage :15,20,25,30,35,40,45,50,60,70,80,90,100

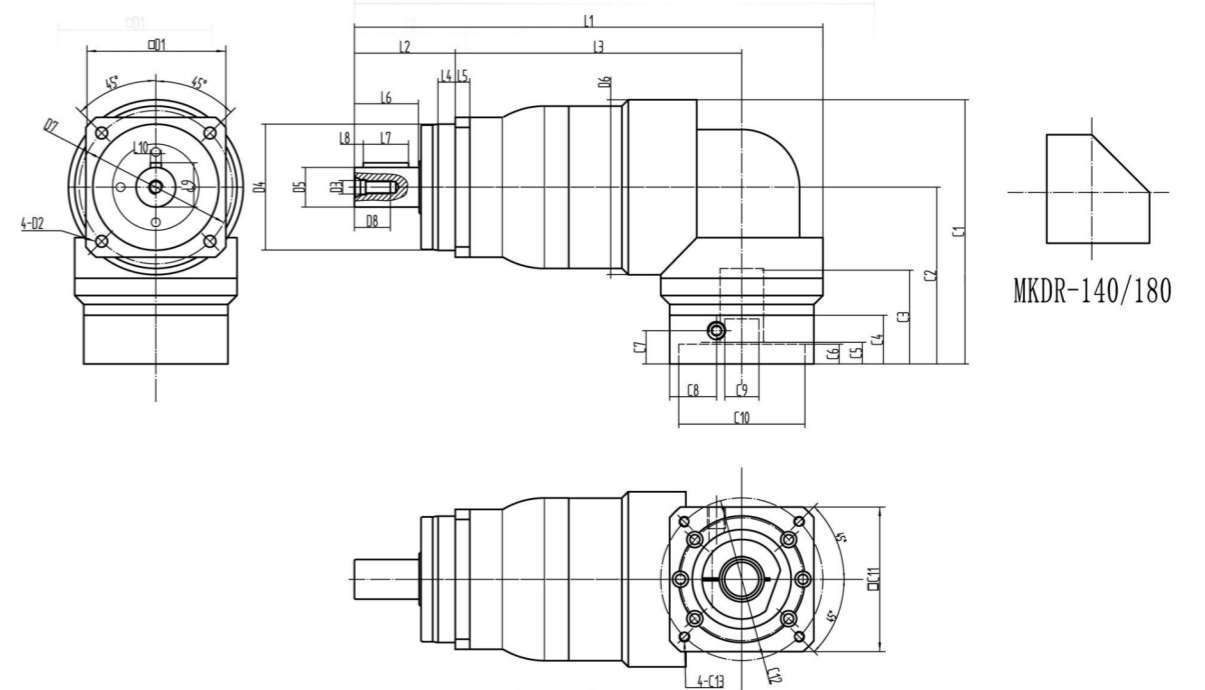

	MKDR-060	MKDR-075	MKDR-100	MKDR-140	MKDR-180
L1*	197.5	260	337.5	416.5	521.5
L2	48	56	80	112	112
L3	117	159	188.5	229.5	319.5
L4	5	10	8	10	27
L5	6	8	10	12	15
L6	28	36	58	82	82
L7	22	25	40	70	70
L8	2	5	10	5	6
L9	18	24.5	35	43	59
L10	5	6	10	12	16
D1	60	77.5	115	140	182
D2	5.5	6.6	9	11	13.5
D3	M5	M8	M12	M16	M20
D4	60	70	90	130	160
D5	16	22	32	40	55
D6	70	97	116	150	205
D7	68	85	130	165	215
D8	12	20	28	36	42
C1*	115.5	146.5	187.5	236.5	295
C2*	80.5	98	126.5	161.5	192.5
C3*	35	53	71	83	95
C4*	23	27	37.5	47	50
C5*	11	12	17	16	18
C6*	10.5	11	10	8	10
C7*	16	18.5	26	26	29
C8*	19.5	26	45	61	70
C9*	14	19	24	35	38
C10*	50	70	110	114.3	180
C11*	60	80	130	176	200
C12*	70	90	145	200	215
C13*	M5*10	M6*12	M8*16	M12*24	M12*24

The one with * is a reference, and the size can be adjusted.

MKDR Series

2-Stage(Smaller type) :15,20,25,30,35,40,45,50,60,70,80,90,100



MKFR SERIES

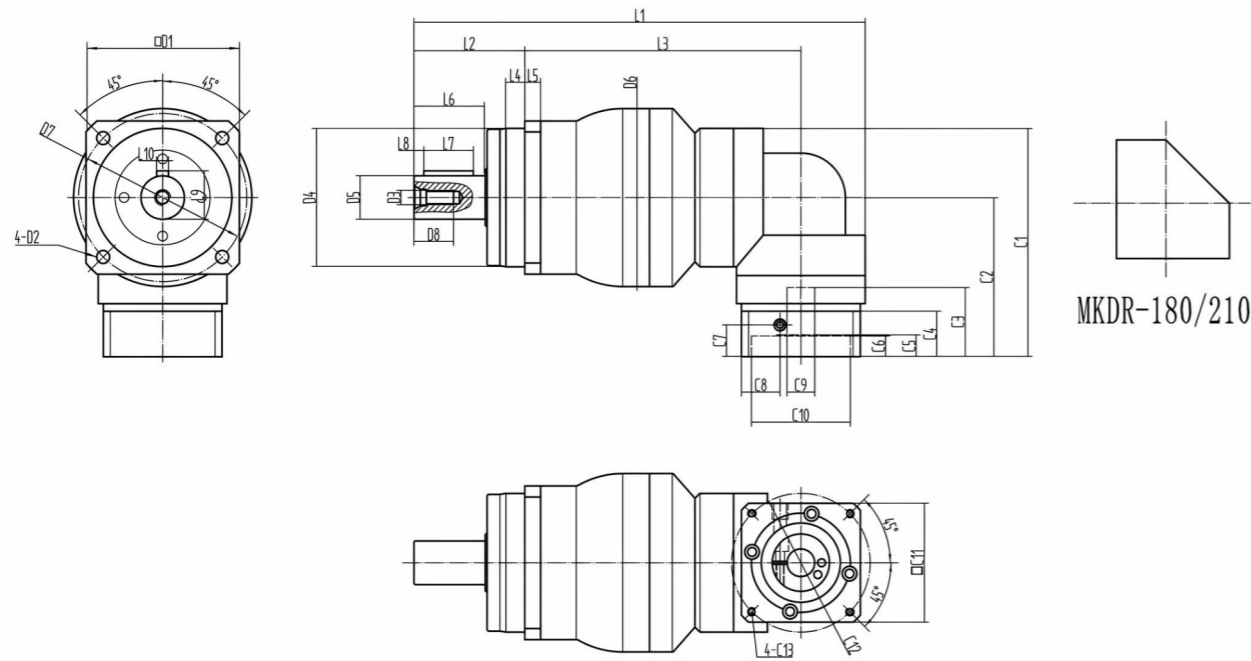

MKDR-180/210

	MKDR-075	MKDR-100	MKDR-140	MKDR-180	MKDR-210
L1*	228	296	377	468	585
L2	56	88	112	112	143
L3	139.5	163	204	281	352
L4	10	8	10	12	15
L5	8	10	12	15	17
L6	36	58	82	82	105
L7	25	40	70	70	90
L8	5	10	5	6	7
L9	24.5	35	43	59	79.5
L10	6	10	12	16	20
D1	77.5	101.5	140	182	210
D2	6.6	9	11	13.5	17
D3	M8	M12	M16	M20	M20
D4	70	90	130	160	180
D5	22	32	40	55	75
D6	90	116	150	205	241
D7	85	120	165	215	250
D8	20	28	36	42	42
C1*	125.5	156	201.5	264	360
C2*	80.5	98	126.5	161.5	239.5
C3*	35	52	71	83	116
C4*	23	27	37.5	47	97
C5*	11	12	17	16	65
C6*	10.5	11	10	8	10
C7*	16	18.5	26	26	76
C8*	19.5	26	45	64	60
C9*	14	19	24	35	42
C10*	50	70	110	114.3	114.3
C11*	60	80	130	176	176
C12*	70	90	145	200	200
C13*	M5*10	M6*12	M8*15	M12*24	M12*28

The one with * is a reference, and the size can be adjusted.

A high-performance right-angle solution for servo applications that keeps MKFR design and characteristics.



Selection data:

Nominal output torque (Nm)	14-2000
Reduction ratio	3-100
Backlash (arcmin)	4-9
Max.working temperature (°C)	90
Noise (dB)	64-74

MKFR

specification	series	Ratio	MKFR-047	MKFR-064	MKFR-090	MKFR-110	MKFR-140	MKFR-200	MKFR-255	
Rated output torque T_{2N}	1	4	19	50	140	320	550	1000	1700	
		5	22	60	160	360	650	1200	2000	
		6	20	55	150	350	600	1100	1900	
		7	20	55	150	360	600	1100	1800	
		8	20	55	140	360	550	1000	1800	
		9	14	40	100	230	450	900	1500	
		10	14	40	100	230	450	900	1500	
		20	19	50	140	320	650	1350	1800	
		25	22	60	160	330	650	1200	2000	
		30	20	55	150	310	650	1100	1900	
	2	35	20	60	150	360	550	1400	1900	
		40	20	55	150	260	500	1000	1600	
		45	14	40	100	230	450	900	1500	
		50	22	60	160	360	700	1400	2000	
		60	20	55	150	310	600	1100	1900	
		70	19	50	140	300	550	1100	1800	
		80	20	55	140	360	700	1400	1900	
		90	14	40	100	230	460	980	1500	
100		14	40	100	230	460	980	1500		
Maximum output torque T_{2M}		Nm	1, 2	3~100	3 times the rated output torque					
Rated input speed n_{1N}	rpm	1, 2	3~100	5000	5000	4000	4000	3000	3000	2000
Maximum input speed n_{2M}	rpm	1, 2	3~100	10000	10000	8000	8000	6000	6000	4000
Backlash accuracy_H (high precision)	arcmin	1	3~10	-	-	-	-	-	-	-
		2	15~100	-	-	-	-	-	-	-
Backlash accuracy_P (precision)	arcmin	1	3~10	≤4	≤4	≤4	≤4	≤4	≤4	≤4
		2	15~100	≤7	≤7	≤7	≤7	≤7	≤7	≤7
Backlash accuracy_S (standard)	arcmin	1	3~10	≤6	≤6	≤6	≤6	≤6	≤6	≤6
		2	15~100	≤9	≤9	≤9	≤9	≤9	≤9	≤9
Torsional rigidity	Nm/arcmin	1, 2	3~100	7	13	31	82	151	450	1023
Allowable radial force F_{2R}	N	1, 2	3~100	55	110	270	440	1335	3280	5500
Allowable axial force F_{2A}	N	1, 2	3~100	990	1050	2850	4000	10590	16660	29430
working life	hr	1, 2	3~100	20000h						
efficiency η	%	1	3~10	≥95%						
		2	15~100	≥92%						
weight	kg	1	3~100	1.1	2.1	5.9	10.5	21.9	50.9	85.4
		2	15~100	1.4	3.2	4.5	10.1	20.1	45.4	85.9
Operating temperature	°C	1, 2	3~100	-15°C~+90°C						
lubrication		1, 2	3~100	IP65						
Ingress protection		1, 2	3~100	life Lubricated						
Mounting direction		1, 2	3~100	Any						
Noise level (n_t=3000rpm)	dB	1, 2	3~100	≤61	≤63	≤65	≤68	≤70	≤72	≤74

specification	series	Ratio	MKFR-047	MKFR-064	MKFR-090	MKFR-110	MKFR-140	MKFR-200	MKFR-255
Inertia J₁	1	4~10	0.09	0.35	2.25	6.84	21.8	95.6	135.4
	2	20~100	0.09	0.09	0.35	2.25	6.84	21.8	95.6

The output speed of F_{2R} and F_{2A} is 100 rpm, acting at the center of the output shaft.

MKFR Series

1-Stage:3,4,5,6,7,8,9,10

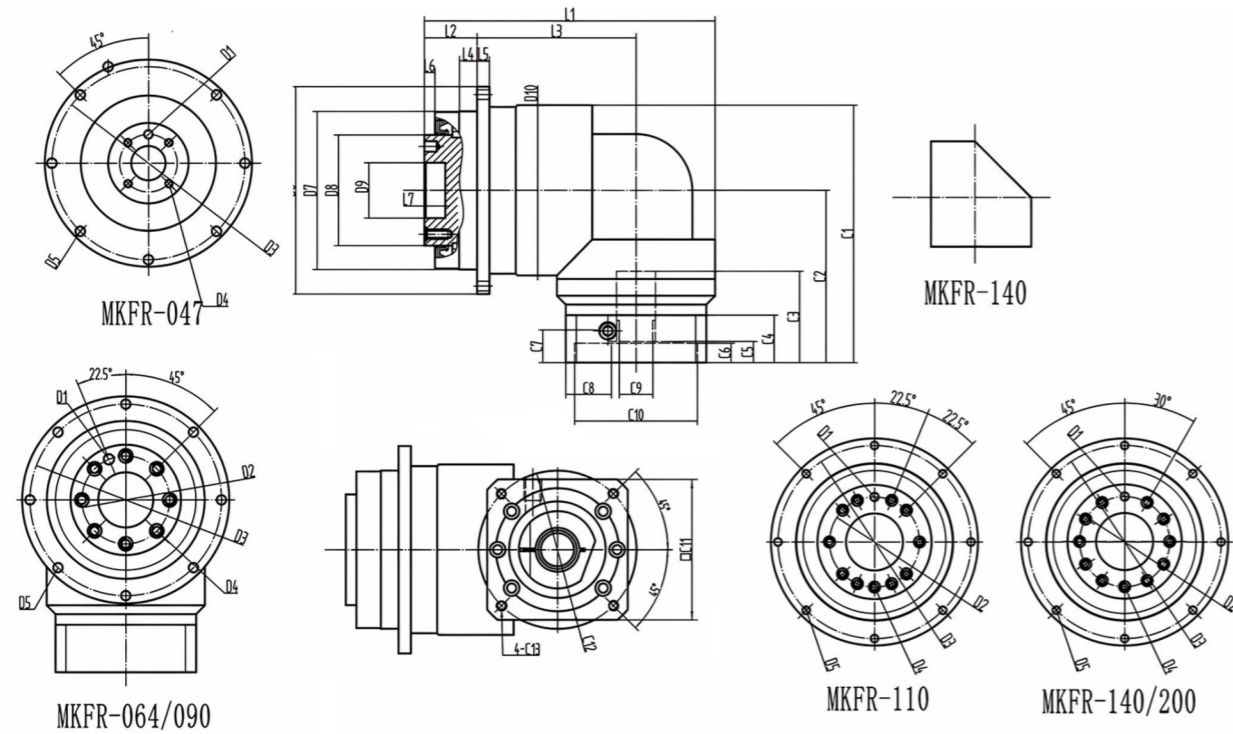

	MKFR-047	MKFR-064	MKFR-090	MKFR-110	MKFR-140	MKFR-200
L1*	88	126.5	165.5	212	255	320.5
L2	19.5	19.5	30	29	38	50
L3	47.5	74.5	90.5	122	142	270.5
L4	7	7	10	10	14.5	15
L5	4	4	7	8	10	12
L6	3	3	6	6	6	8
L7	4	8	12	13	12	16
D1	φ 3*4	φ 5*8	φ 6*7	φ 6*7	φ 8*7	φ 10*10
D2	20	31.5	50	63	80	125
D3	67	79	109	135	168	233
D4	4-M3*6	7-M5*8	8-M6*12	11-M6*12	11-M8*17	11-M10*20
D5	8-φ 3.4	8-φ 4.5	8-φ 5.5	8-φ 5.5	12-φ 6.6	12-φ 9
D6	72	86	118	145	179	247
D7	47	64	90	110	140	200
D8	28	40	63	80	100	160
D9	12	20	31.5	40	50	80
D10	60	70	97	124	150	200
C1*	83	115.5	146.5	187.5	251	287.5
C2*	47	80.5	98	126.5	161.5	187.5
C3*	27	35	52	71	83	90
C4*	17.5	23	27	37.5	47	45
C5*	7	11	11	17	16	15
C6*	3.5	10.5	11	10	8	10
C7*	11.5	16	18.5	26	26	24
C8*	14.5	19.5	26	42.5	61	60
C9*	8	14	19	24	35	42
C10*	30	50	70	110	114.3	114.3
C11*	42	60	80	130	176	180
C12*	46	70	90	145	200	200
C13*	M4*8	M5*10	M6*12	M8*16	M12*24	M12*24

The one with * is a reference, and the size can be adjusted.

MKFR Series

2-Stage :15,20,25,30,35,40,45,50,60,70,80,90,100

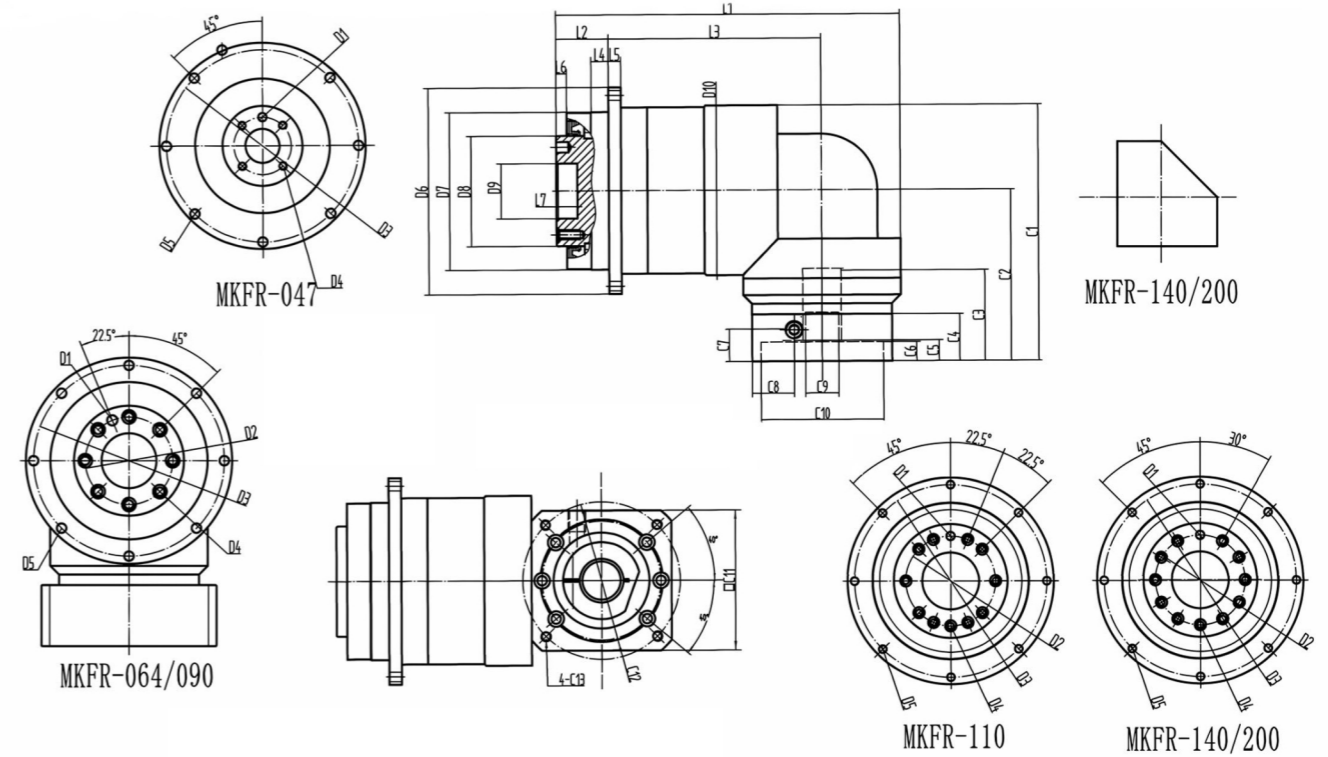

	MKFR-047	MKFR-064	MKFR-090	MKFR-110	MKFR-140	MKFR-200
L1*	105.5	150	196.5	249	309.5	372.5
L2	19.5	19.5	30	29	38	50
L3	65	98	121.5	159	196.5	229.5
L4	7	7	10	10	14.5	15
L5	4	4	7	8	10	12
L6	3	3	6	6	6	8
L7	4	8	12	13	12	16
D1	φ 3*4	φ 5*8	φ 6*7	φ 6*7	φ 8*7	φ 10*10
D2	20	31.5	50	63	80	125
D3	67	79	109	135	168	233
D4	4-M3*6	7-M5*8	8-M6*12	11-M6*12	11-M8*17	11-M10*20
D5	8-φ 3.4	8-φ 4.5	8-φ 5.5	16-φ 5.5	12-φ 6.6	12-φ 9
D6	72	86	118	145	179	247
D7	47	64	90	110	140	200
D8	28	40	63	80	100	160
D9	12	20	31.5	40	50	80
D10	60	70	97	124	150	200
C1*	83	115.5	146.5	187.5	236.5	292.5
C2*	47	80.5	98	126.5	161.5	192.5
C3*	27	35	53	71	83	95
C4*	17.5	23	27	37.5	47	50
C5*	7	11	12	17	16	20
C6*	3.5	10.5	11	10	8	10
C7*	11.5	16	18.5	26	26	29
C8*	14.5	19.5	26	42.5	61	70
C9*	8	14	19	24	35	38
C10*	30	50	70	110	114.3	180
C11*	42	60	80	130	176	200
C12*	46	70	90	145	200	215
C13*	M4*8	M5*10	M6*12	M8*16	M12*25	M12*24

The one with * is a reference, and the size can be adjusted.

